

---

# Sump, Effluent and Sewage

REPAIR PARTS

---

### INDEX

#### SUMP, EFFLUENT AND SEWAGE

ST .....	3
PE .....	4
3871 (EP04 & EP05).....	5
PS 41/51 .....	6
PV51 - Vortex .....	7
3872 (WW05) .....	8
1/2DM, 1/2DV .....	9
1DW .....	10
2DW .....	11
1SC and SE .....	12
3885 (WE --- L, M, H, HH).....	14
2ED .....	16
3886/3887 (WS - B, BF, BHF).....	18
3887BF (WS - BF) .....	20
3887BHF (WS --- BHF) .....	21
2WD/3WD (1725).....	22
2WD/3WD (3500).....	24
3888D3/D4 (WS --- D3, D4).....	26
3SD/4SD .....	26
3SDX/4SDX.....	28
1GD .....	30
4NS/4XD .....	32
RGS2012 .....	34
AGS0511/AGS0512.....	35
AGS1011/AGS1012.....	36
1GA/2GA .....	37
Oil Volumes .....	37
Submersible Vortex .....	37
Control Panel Repair Parts .....	38
A10-12, A10-2015 and A10-20 .....	39

**Note:** Repair Motor List Prices are in the "K", "L" and Numeric Repair Part Price Book.

4K432 OIL SPECIFICATION:  
5 gallon can of ASTM 150 Turbine Oil

#### **COMPARABLE BRAND NAMES:**

Sunoco	Sunvis 932
Mobil	DTE Light
Texaco	Regal R&O 32
Shell	Turbo 32
Gulf	Harmony 32
Amoco	Am. Industries Oil 32
Exxon	Nuto 32
Chevron	GST 32

### MODEL ST31/51/71

Item	Part Name	Description	Part No.
1	1/3 HP Motor Assembly - 115 Volt	Motor, Seal Housing, Receptacle, Jam Nut, O-Ring, Mechanical Seal, Impeller	15K88
	1/2 HP Motor Assembly - 115 Volt		15K89
	3/4 HP Motor Assembly - 115 Volt		15K90
2	Base Assembly	Base, Gasket, Screws	15K27
3	Cord Set - 115 Volt	10' Cord Set with 5-15P Nema Plug (used with piggyback float)	9K587
	Cord Set - 115 Volt	20' Cord Set with 5-15P Nema Plug (used with piggyback float)	9K588
4	Cord Set - 115 Volt and float assembly	10' Pumpmaster with bracket-cord	9K593
5	Cord Set - 115 Volt and float assembly	10' Verticalmaster with bracket-cord	9K586

\*Pumps with cords before 2/1/12 can not be repaired.

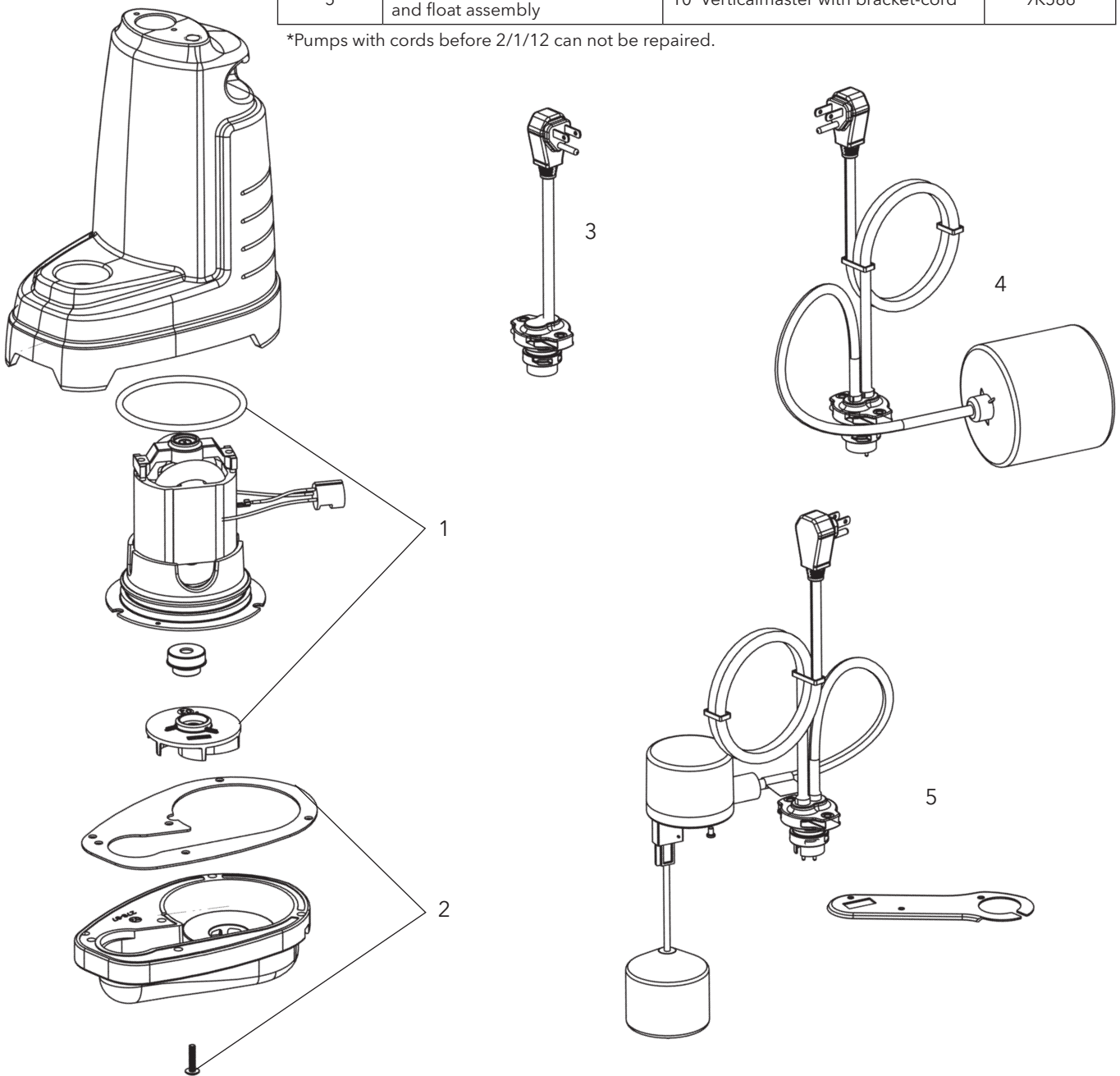

### ALL MODELS PE AND ST51/71

Item No.	Part Name	Description	After 2/1/12 Part No.
1	1/3 HP Motor Assembly - 115V	Motor, Seal Housing, Receptacle, Jam Nut, O-ring, Mechanical Seal, Impeller	15K88
	4/10 HP Motor Assembly - 115V		15K89
	1/2 HP Motor Assembly - 115V		15K90
	4/10 HP Motor Assembly - 230V		15K93
	1/2 HP Motor Assembly - 230V		15K94
2	Base Assembly	Base, Gasket, Screws	15K27
3	Cord Set - 115V	10' Manual - 115V with 5-15P Nema Plug	9K587
4		20' Manual - 115V with 5-15P Nema Plug - Standard	9K588
5		30' Manual - 115V with 5-15P Nema Plug	9K595
6		50' Manual - 115V with 5-15P Nema Plug	9K590
		30' Pumpmaster - 115V with 5-15P Nema Plug	9K594
-		Cord Set - 230V	20' Manual - 230V with 6-15P Nema Plug - Standard
-	30' Manual - 230V with 6-15P Nema Plug		9K592
-	Float Switch - 115V	10' Pumpmaster with Hardware - 115V, 13A	A2D11
		20' Pumpmaster with Hardware - 115V, 13A	A2D31
		30' Pumpmaster with Hardware - 115V, 13A	A2D51
-	Float Switch - 230V	20' Pumpmaster with Hardware - 230V, 13A	A2D32
		30' Pumpmaster with Hardware - 230V, 13A	A2D52

\*Pumps with cords before 2/1/12 can not be repaired.

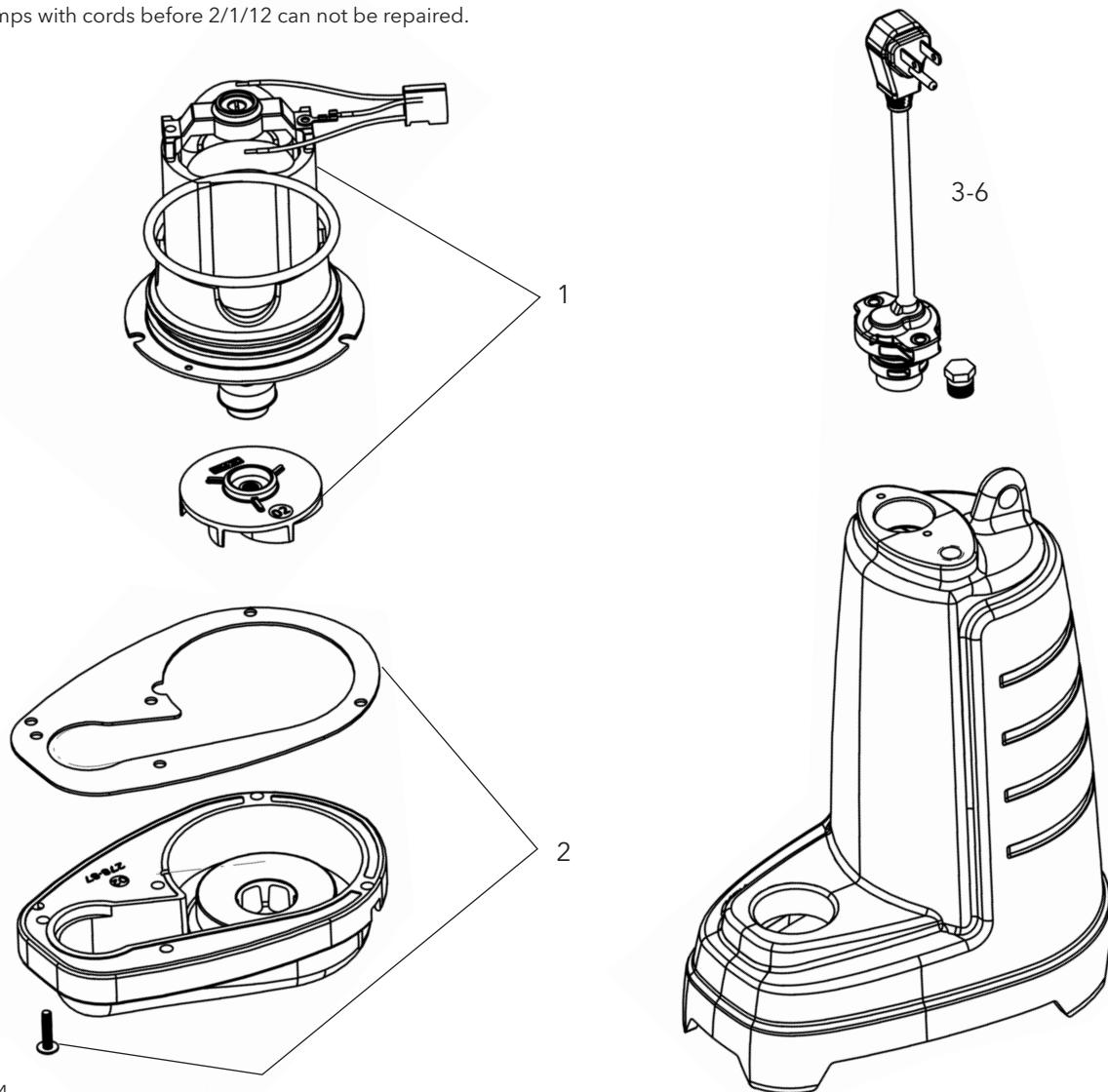

### MODEL 3871 - EP04/EP05 Series

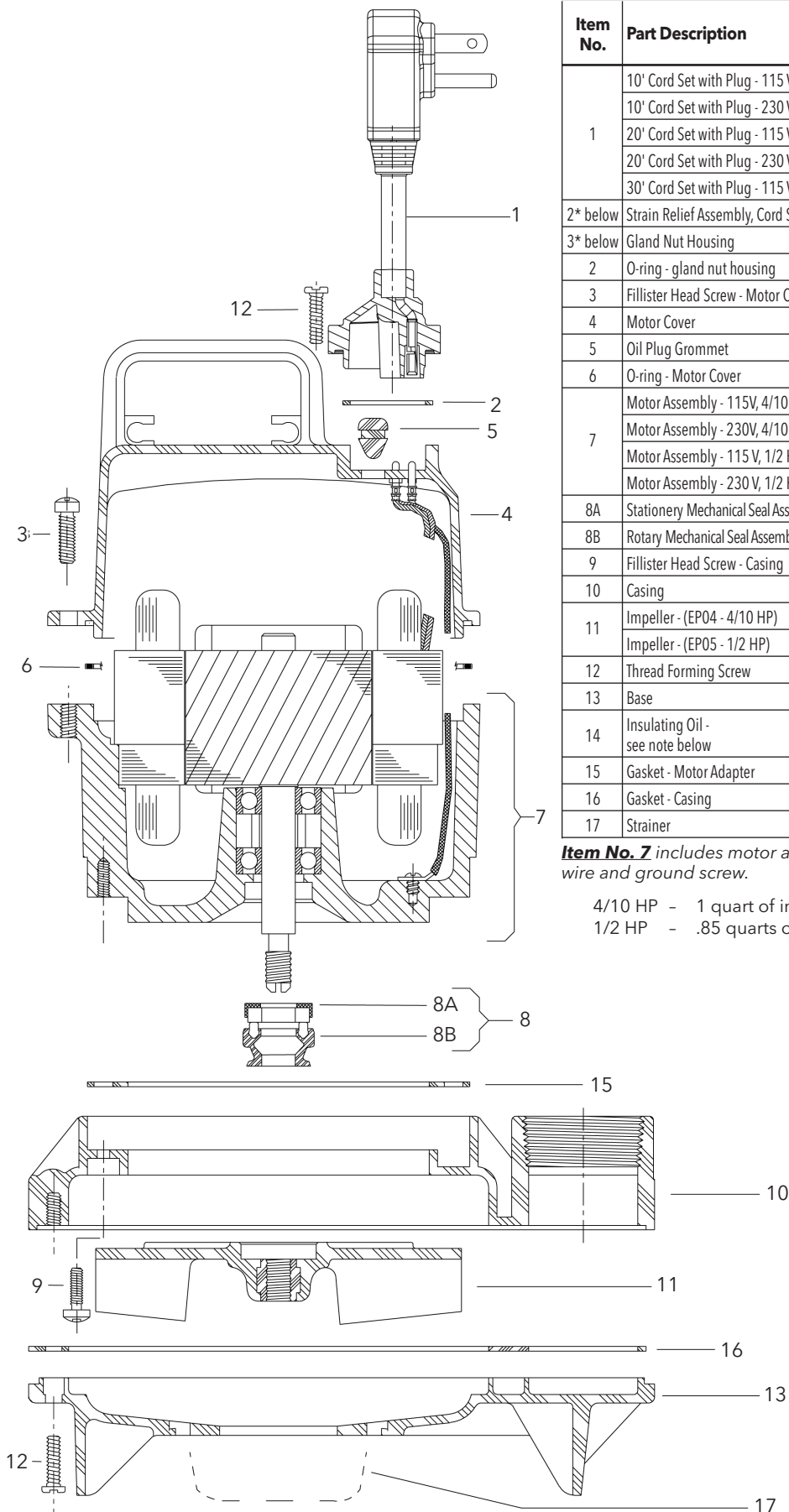

Item No.	Part Description	Material	Qty. Req.	Before 2/1/12 Part No.	After 2/1/12 Part No.
1	10' Cord Set with Plug - 115 V	SJTOW - 16/3	1	9K207	9K531
	10' Cord Set with Plug - 230 V			9K208	9K532
	20' Cord Set with Plug - 115 V			9K533	9K533
	20' Cord Set with Plug - 230 V			9K210	9K534
	30' Cord Set with Plug - 115 V*			9K403	9K536
2* below	Strain Relief Assembly, Cord Set	Varies	1	5K113	not needed
3* below	Gland Nut Housing	Thermoplastic	1	9K226	not needed
2	O-ring - gland nut housing	Buna-N, AS 568A-024	1	5K197	5K197
3	Fillister Head Screw - Motor Cover	AISI 300 SS	4	13K347	13K347
4	Motor Cover	Thermoplastic	1	1K257	1K257
5	Oil Plug Grommet	Buna-N	1	6K87	6K87
6	O-ring - Motor Cover	Buna-N, AS 568A-161	1	5K196	5K196
7	Motor Assembly - 115V, 4/10 HP	Varies	1	1K282	1K282
	Motor Assembly - 230V, 4/10 HP			1K283	1K283
	Motor Assembly - 115 V, 1/2 HP			1K284	1K284
	Motor Assembly - 230 V, 1/2 HP			1K285	1K285
8A	Stationery Mechanical Seal Assembly	Carbon/Ceramic	1	10K32	10K32
8B	Rotary Mechanical Seal Assembly				
9	Fillister Head Screw - Casing	AISI 300 SS	4	13K347	13K347
10	Casing	Thermoplastic	1	1K233	1K233
11	Impeller - (EP04 - 4/10 HP)	Thermoplastic	1	2K498	2K498
	Impeller - (EP05 - 1/2 HP)			2K731	2K731
12	Thread Forming Screw	AISI 300 SS	10	13K243	13K243
13	Base	Thermoplastic	1	1K258	1K258
14	Insulating Oil - see note below	Turbine Oil - ATSM 150	-	4K432	4K432
15	Gasket - Motor Adapter	Composite	1	5K182	5K182
16	Gasket - Casing	Composite	1	5K219	5K219
17	Strainer	Thermoplastic	1	4K528	4K528

**Item No. 7** includes motor adapter, rotor, stator, tolerance ring, ground wire and ground screw.

4/10 HP - 1 quart of insulating oil required.

1/2 HP - .85 quarts of insulating oil required.

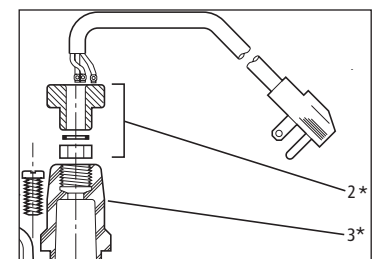

\* Not needed after 2/1/2012.

**NOTE:** Pump with cord sets previous to 2/1/2012 can not be repaired after 2/1/2012.

**NOTE:** After 5/11, new cord design eliminates gland as separate component.

### MODEL PS41, 51

Item Number	Part Name	Description	Before 2/1/12 Part Number	After 2/1/12 Part Number
1	4/10 HP Motor Assembly - 115V	Motor, Seal Housing, Receptacle, Jam Nut, O-ring, Mechanical Seal, Impeller	15K30	15K91
	1/2 HP Motor Assembly - 115V		15K31	15K92
	4/10 HP Motor Assembly - 230V		15K47	15K95
	1/2 HP Motor Assembly - 230V		15K48	15K96
2	Base Assembly	Base, Gasket, Screws	15K39	15K39
3	Cord Set - 115V	10' Manual - 115V with 5-15P Nema Plug	9K372	9K587
4		20' Manual - 115V with 5-15P Nema Plug - Standard	9K375	9K588
5		30' Manual - 115V with 5-15P Nema Plug	9K380	9K595
6		50' Manual - 115V with 5-15P Nema Plug	9K377	9K590
		30' Pumpmaster - 115V with 5-15P Nema Plug	9K446	9K594
-		Cord Set - 230V	20' Manual - 230V with 6-15P Nema Plug - Standard	9K421
-	30' Manual - 230V with 6-15P Nema Plug		9K422	9K592
-	Float Switch - 115V	10' Pumpmaster with Hardware - 115V, 13A	A2D11	A2D11
		20' Pumpmaster with Hardware - 115V, 13A	A2D31	A2D31
		30' Pumpmaster with Hardware - 115V, 13A	A2D51	A2D51
-	Float Switch - 230V	20' Pumpmaster with Hardware - 230V, 13A	A2D32	A2D32
		30' Pumpmaster with Hardware - 230V, 13A	A2D52	A2D52

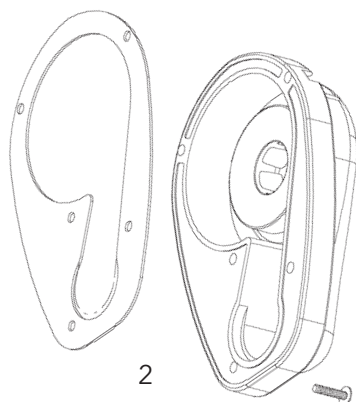
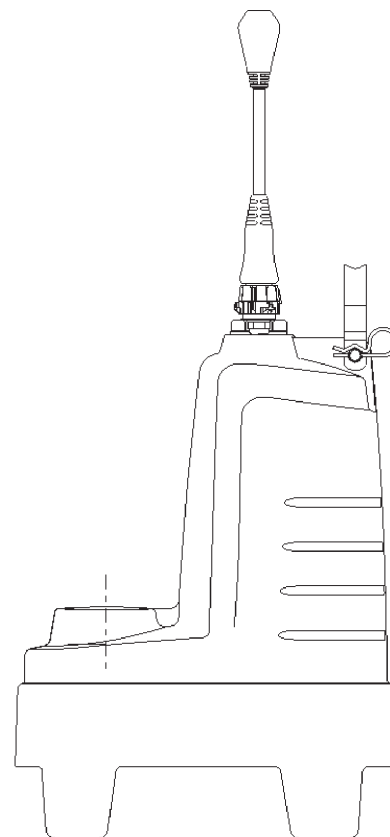
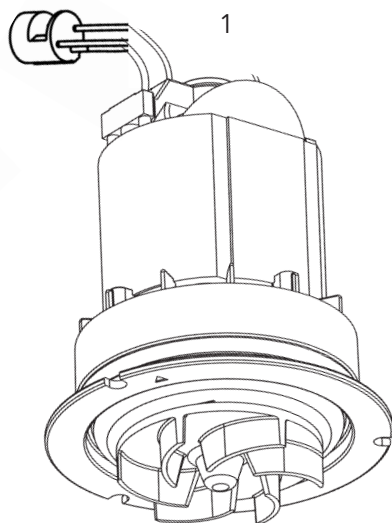
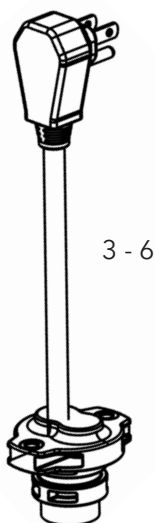

### MODEL PV51 - Vortex

Item Number	Part Name	Description	Before 2/1/12 Part Number	After 2/1/12 Part Number	
1	½ HP Motor Assembly - 115V	Motor, Seal Housing, Receptacle, Jam Nut, O-Ring, Mechanical Seal, Impeller	15K58	15K102	
	½ HP Motor Assembly - 230V		15K59	15K104	
	¾ <sub>10</sub> HP Motor Assembly - 115V			15K101	
	¾ <sub>10</sub> HP Motor Assembly - 230V			15K103	
2	Base Assembly	Base, Gasket, Screws	15K57	15K57	
3	Cord Set - 115V	10' Manual - 115V with 5-15P Nema Plug	9K372	9K587	
4		20' Manual - 115V with 5-15P Nema Plug - Standard	9K375	9K588	
5		30' Manual - 115V with 5-15P Nema Plug	9K380	9K595	
6		50' Manual - 115V with 5-15P Nema Plug	9K377	9K590	
7		30' Pumpmaster - 115V with 5-15P Nema Plug	9K446	9K594	
8		Cord Set - 230V	20' Manual - 230V with 6-15P Nema Plug - Standard	9K421	9K591
9			30' Manual - 230V with 6-15P Nema Plug	9K422	9K592
10	Float Switch - 115V	10' Pumpmaster with Hardware - 115V, 13A	A2D11	A2D11	
		20' Pumpmaster with Hardware - 115V, 13A	A2D31	A2D31	
		30' Pumpmaster with Hardware - 115V, 13A	A2D51	A2D51	
11	Float Switch - 230V	20' Pumpmaster with Hardware - 230V, 13A	A2D32	A2D32	
		30' Pumpmaster with Hardware - 230V, 13A	A2D52	A2D52	

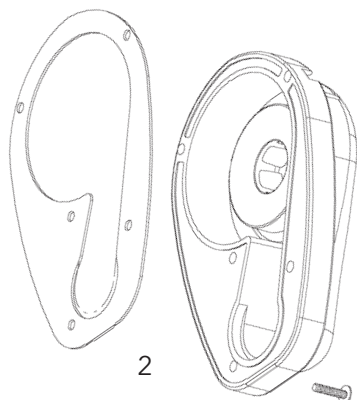
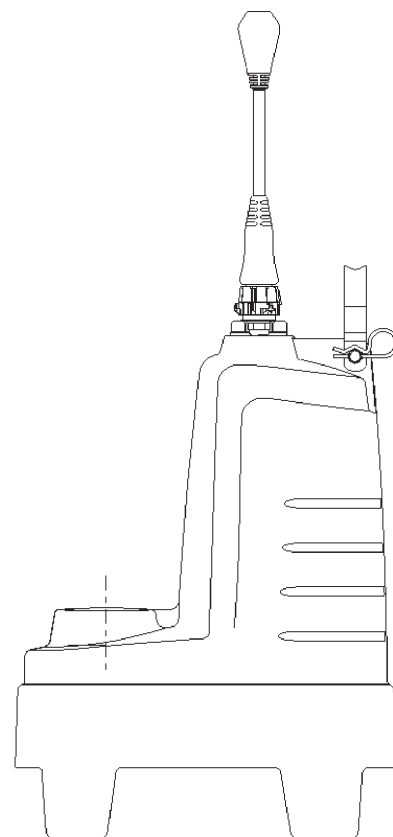
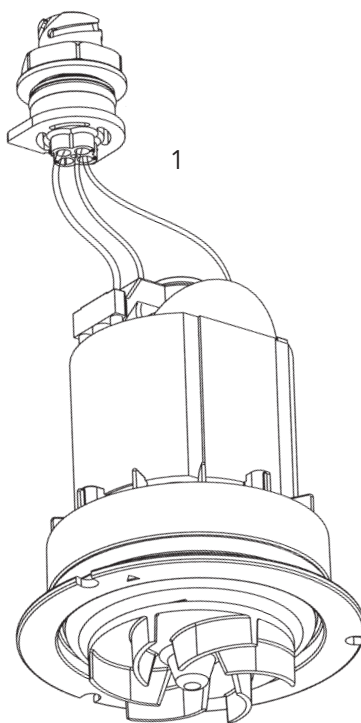
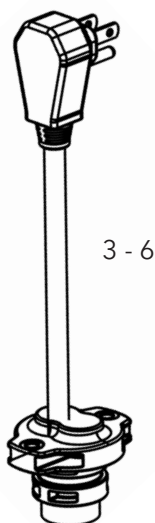

### MODEL 3872 - WW05 Series

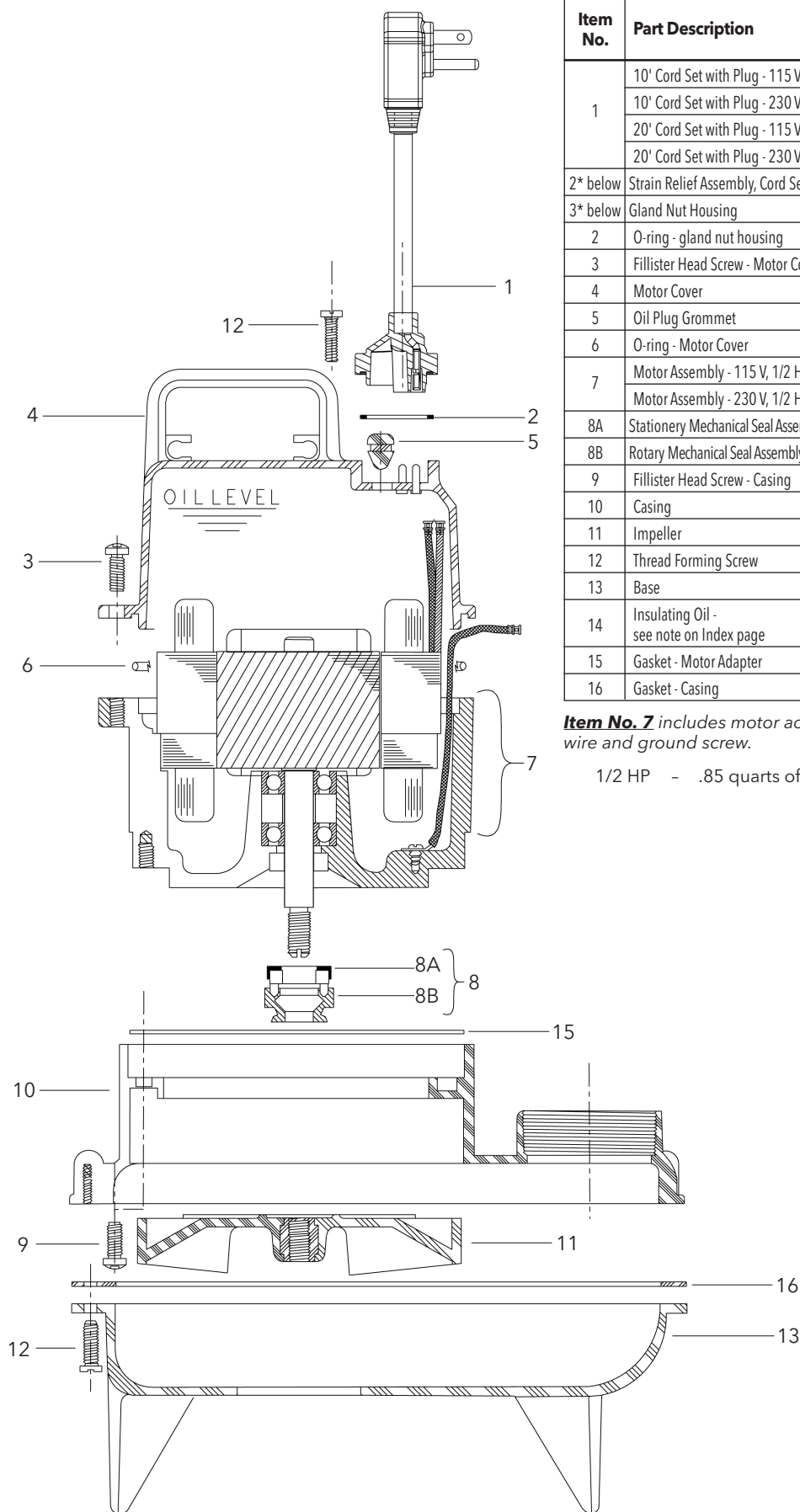

Item No.	Part Description	Material	Qty. Req.	Before 2/1/12 Part No.	After 2/1/12 Part No.
1	10' Cord Set with Plug - 115 V	SJTOW - 16/3	1	9K207	9K531
	10' Cord Set with Plug - 230 V			9K208	9K532
	20' Cord Set with Plug - 115 V			9K533	9K533
	20' Cord Set with Plug - 230 V			9K210	9K534
2* below	Strain Relief Assembly, Cord Set	Varies	1	5K113	not needed
3* below	Gland Nut Housing	Thermoplastic	1	9K226	not needed
2	O-ring - gland nut housing	Buna-N, AS 568A-024	1	5K197	5K197
3	Fillister Head Screw - Motor Cover	AISI 300 SS	4	13K347	13K347
4	Motor Cover	Thermoplastic	1	1K257	1K257
5	Oil Plug Grommet	Buna-N	1	6K87	6K87
6	O-ring - Motor Cover	Buna-N, AS 568A-161	1	5K196	5K196
7	Motor Assembly - 115 V, 1/2 HP	Varies	1	1K284	1K284
	Motor Assembly - 230 V, 1/2 HP			1K285	1K285
8A	Stationery Mechanical Seal Assembly	Carbon/Ceramic	1	10K32	10K32
8B	Rotary Mechanical Seal Assembly				
9	Fillister Head Screw - Casing	AISI 300 SS	4	13K347	13K347
10	Casing	Thermoplastic	1	1K274	1K274
11	Impeller	Thermoplastic	1	2K494	2K494
12	Thread Forming Screw	AISI 300 SS	10	13K243	13K243
13	Base	Thermoplastic	1	1K275	1K275
14	Insulating Oil - see note on Index page	Turbine Oil - ATSM 150	-	4K432	4K432
15	Gasket - Motor Adapter	Composite	1	5K182	5K182
16	Gasket - Casing	Composite	1	5K217	5K217

**Item No. 7** includes motor adapter, rotor, stator, tolerance ring, ground wire and ground screw.

1/2 HP - .85 quarts of insulating oil required.

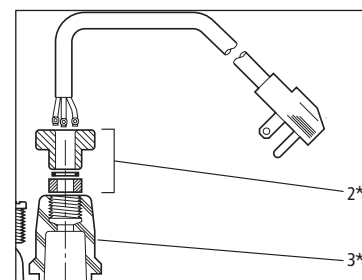

\* Not needed after 2/1/2012.

**NOTE:** Pump with cord sets previous to 2/1/2012 can not be repaired after 2/1/2012.

**NOTE:** After 5/11, new cord design eliminates gland as separate component.



### MODEL 1/2DM, 1/2DV

Item Number	Part Description	Repair Parts Order Number			
		½ HP	¾ HP	1 HP	1½ HP
1	Base Package (Suction Flange, Feet, Screws)	15L1		15L2	
2	<b>DV</b> Impeller Package (Impeller, Screw, Key, V-Ring)	15L3	15L4	15L5	15L6
	<b>DM</b> Impeller Package (Impeller, Screw, Key, V-Ring)	15L7	15L8	15L9	15L10
3	Pump Seal Package (V-Ring, Mechanical Seal, O-Rings)	15L11			
4*	Cord / Handle / Capacitor Box Assembly	115V, Single Phase	15L60	N/A	
	Cord / Handle Assembly	230V, Single Phase	15L61		N/A
		230V/460V, Three Phase	15L62		
5	Capacitor Box / Cord Assembly	15L51	N/A	15L57*	N/A
6	Capacitor - pumps built after June, 2002	115V, Single Phase	9L122	N/A	
		230V, Single Phase	9L113	9L123	9L124

\* After 11/04 - cord/handle/capacitor box assembly is not available for units built prior to 11/04

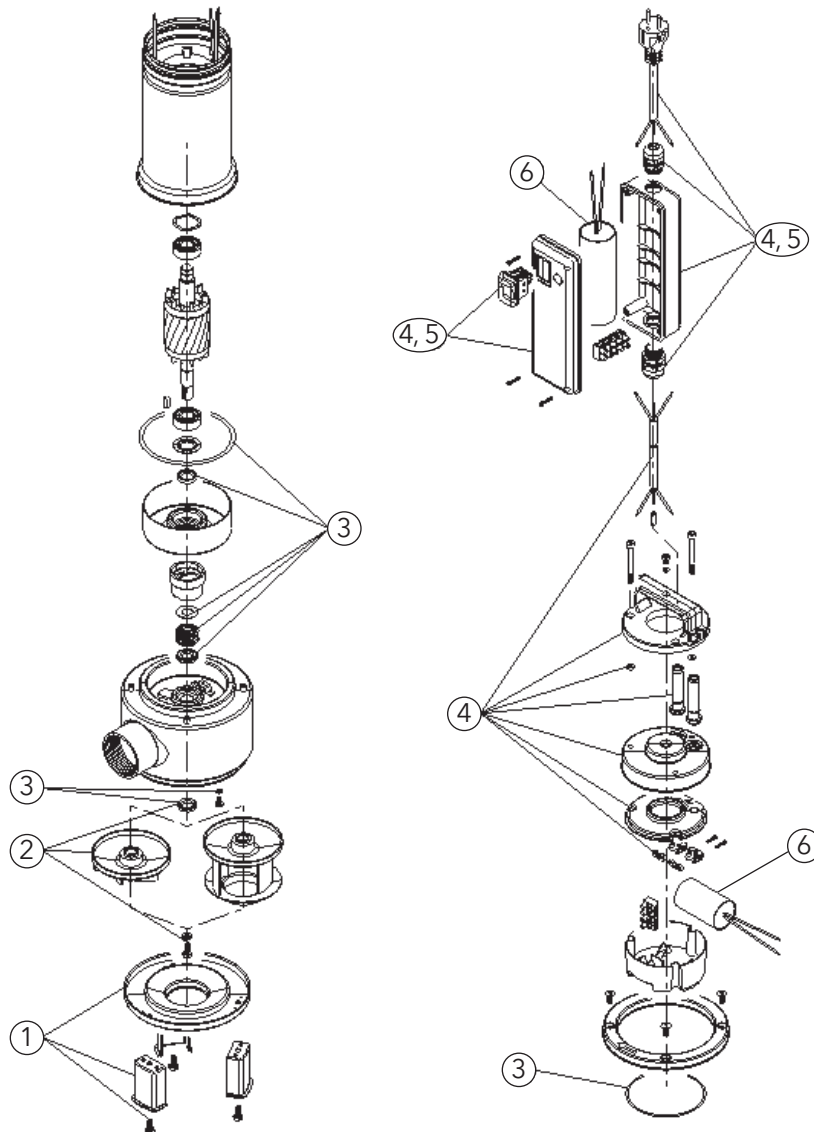

### MODEL 1DW

Item Number	Part Description	Repair Parts Order Number			
		½ HP	¾ HP	1 HP	1½ HP
1	Strainer Package (Suction Flange and Strainer)	15L17			
2	Impeller Package (Impeller, Screw, Key, V-Ring)	15L19	15L20	15L21	15L22
3	Pump Seal Package (V-Ring, Mechanical Seal, O-Rings)	15L23			
4	Cord / Handle / Capacitor Box Assembly	115V, Single Phase	15L54	N/A	
		230V, Single Phase	15L55		N/A
	Cord / Handle Assembly	230/460V, Three Phase			
5	Capacitor Box / Cord Assembly	15L51		15L16	N/A
6	Capacitor - pumps built after June, 2002	115V, Single Phase	9L117	N/A	
		230V, Single Phase	9L113	9L123	9L124

Capacitors not available for pumps before June, 2002.

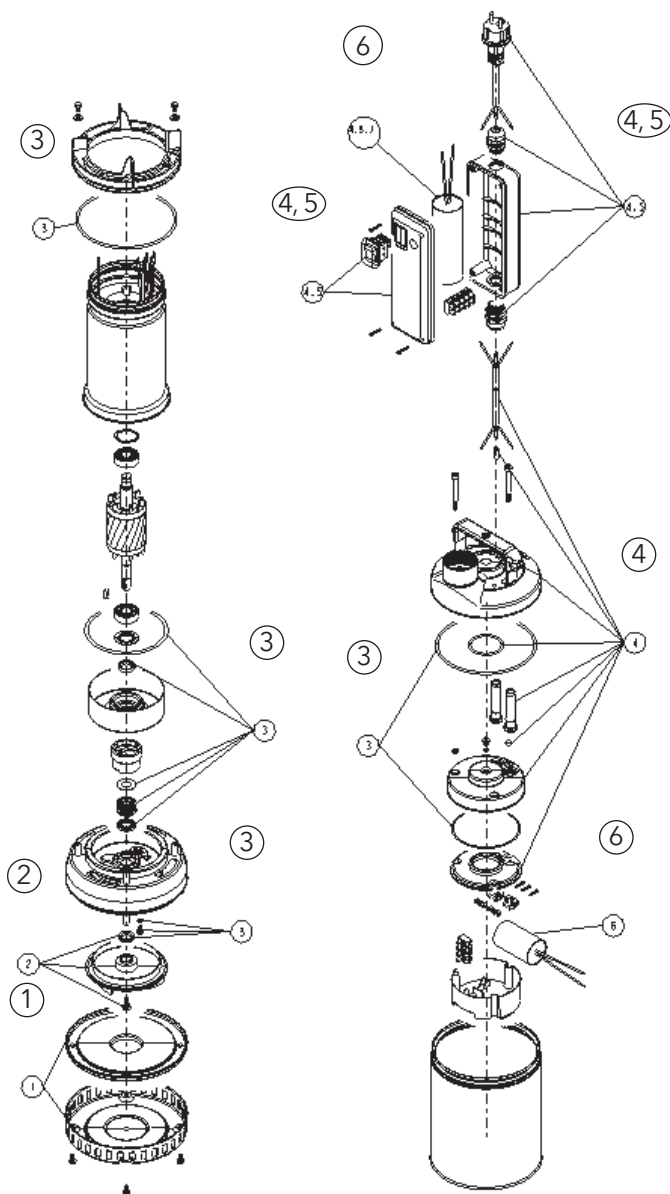

### MODEL 2DW

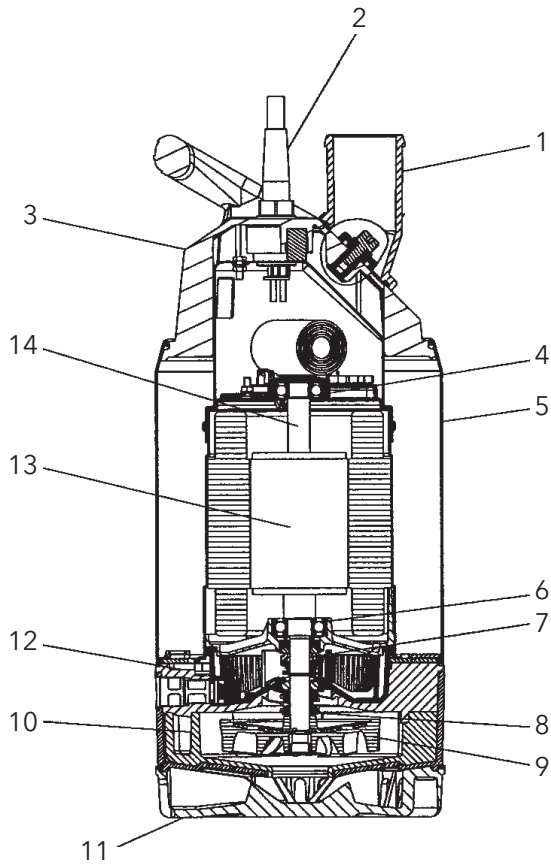

Item No.	Part Description	Quantity Required	Repair Part Order No. After 8/05
1	Discharge Connection Kit	1	6K173
2	Cordset - 1 Phase, 115V		9K598
	Cordset - 1 Phase, 230V		9K599
3	Handle / Cover		-
4	Bearing - Upper		-
5	Casing		-
6	Bearing - Lower		-
7	Mechanical Seal - Lower		-
8	Mechanical Seal - Upper		-
9	Impeller		-
10	Diffuser		-
11	Strainer		-
12	Plug - Oil		-
13	Motor	-	
<b>Kits</b>		<b>Kit</b>	
Impeller - ½ HP	Impeller, Impeller Screw, Protective Plug, Washer, Assembly Instructions	1	15K97
Impeller - 1 HP			15K98
Diffuser	Diffuser, Screws, Washers, Assembly Instruction		15K99
Mechanical Seal - Lower	Mechanical Face-Seal Unit, Assembly Instruction		15K14
Mechanical Seal - Upper and Lower	Complete Mechanical Seal Kit		15K41
Ball Bearing Kit	Upper and Lower Ball Bearings		15K42
O-Ring Kit (Complete Set)	Complete O-Ring Set		15K100

**MODELS SE and 1SC**

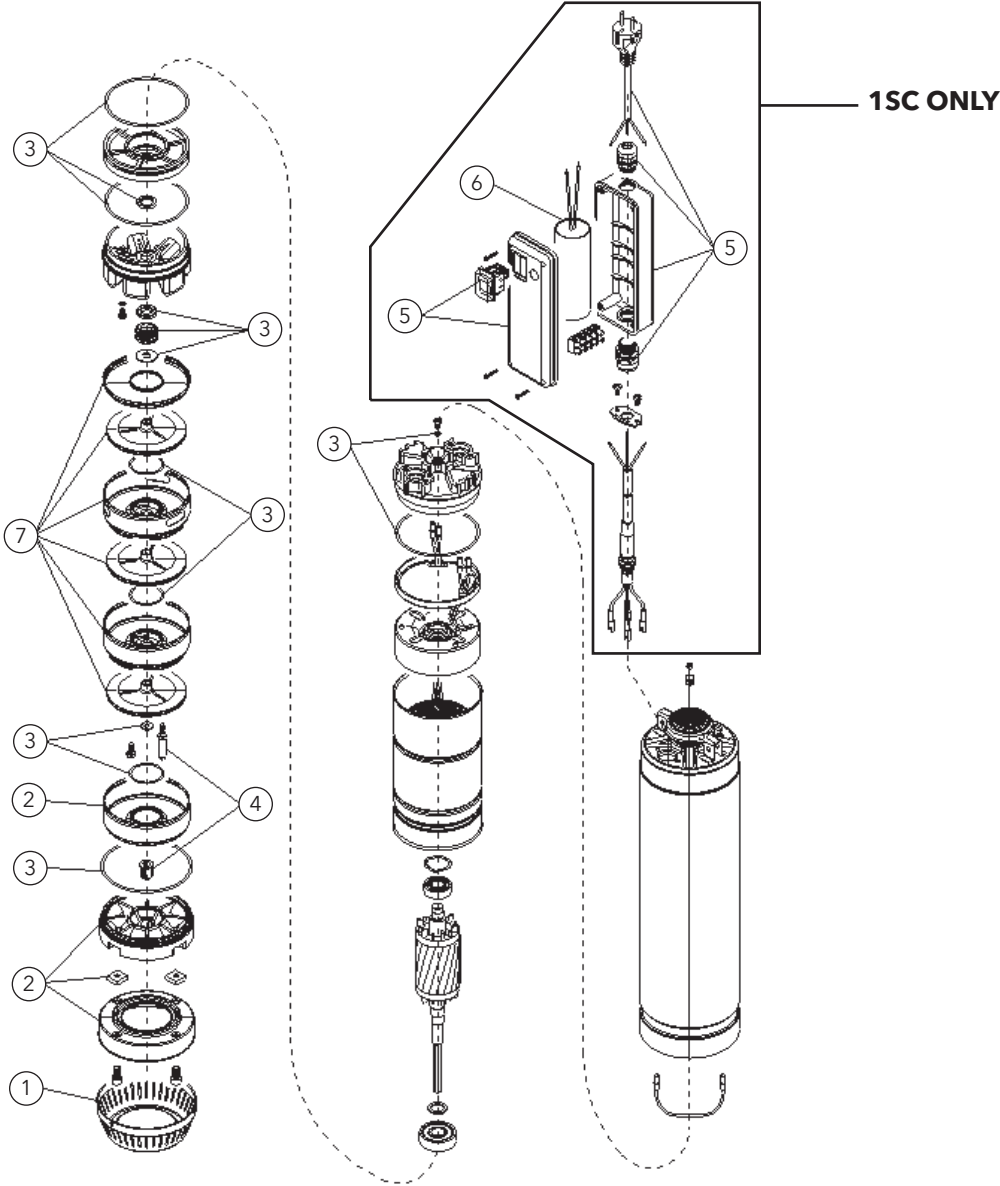

### MODEL SE

Item Number	Part Description		Repair Parts Order Number		
			8SE	16SE	26SE
1	Suction Strainer		15L28		
2	Lower Bearing Support Package		15L29		
3	Pump Seal Package (Mechanical Seal and O-Rings) - New		15L52		
4	Bushing Package		15L31	N/A	N/A
5	Power Cord - 16/3 SJTW x 10 ft. with Bare Leads	115V, Single Phase	9L120		
		230V, Single Phase			
6	Capacitor	115V, Single Phase	9L118 (50 mfd, 250V)		
		230V, Single Phase	9L119 (16 mfd, 450V)		
7	Impeller / Diffuser Package		15L53 (4)	15L33 (3)	15L34 (3)

### MODEL 1SC - After 5/06

Item Number	Part Description		Repair Parts Order Number		
			½ HP - 3 Stage	¾ HP - 4 Stage	1 HP - 5 Stage
1	Suction Strainer		15L28		
2	Lower Bearing Support Package		15L29		
3	Pump Seal Package (Mechanical Seal and O-Rings) - New		15L52		
4	Bushing Package		N/A		15L31
5	Capacitor Box / Cord Assembly Cord Assembly	115V, Single Phase	15L51	N/A	
		230V, Single Phase	9L121 (6-15P Plug)		
		230V, Three Phase	9L125		
6	Capacitor	115V, Single Phase	No Longer Available		
		230V, Single Phase	9L114 (25 mfd, 450V)		9L124 (30 mfd, 450V)
7	Impeller / Diffuser Package - Low Flow		15L33 (3)	15L33 (4)	15L33 (5)
	Impeller / Diffuser Package - High Flow		15L34 (3)	15L34 (4)	15L34 (5)

### MODEL 1SC - 6/02 to 5/06

Item Number	Part Description		Repair Parts Order Number		
			½ HP - 3 Stage	¾ HP - 4 Stage	1 HP - 5 Stage
1	Suction Strainer		15L28		
2	Lower Bearing Support Package		15L29		
3	Pump Seal Package (Mechanical Seal and O-Rings) - New		(15L30 Obs.) - 15L52		
4	Bushing Package		15L31		
5	Capacitor Box / Cord Assembly	115V, Single Phase	15L51	N/A	
		230V, Single Phase	15L16		15L57
6	Capacitor	115V, Single Phase	9L122 (70 mfd, 250V)	N/A	
		230V, Single Phase	9L114 (25 mfd, 450V)		9L124 (30 mfd, 450V)
7	Impeller / Diffuser Package - Low Flow		15L33 (3)	15L33 (4)	15L33 (5)
	Impeller / Diffuser Package - High Flow		15L34 (3)	15L34 (4)	15L34 (5)

### MODEL 1SC - 4/97 to 6/02

Item Number	Part Description		Repair Parts Order Number		
			½ HP - 3 Stage	¾ HP - 4 Stage	1 HP - 5 Stage
1	Suction Strainer		15L28		
2	Lower Bearing Support Package		15L29		
3	Pump Seal Package (Mechanical Seal and O-Rings) - New		(15L30 Obs.) - 15L52		
4	Bushing Package		15L31		
5	Capacitor Box / Cord Assembly	230V, Single Phase	15L16		15L32
6	Capacitor	115V, Single Phase	No Longer Available		
		230V, Single Phase	9L113 (20 mfd, 450V)		9L114 (25 mfd, 450V)
7	Impeller / Diffuser Package - Low Flow		15L33 (3)	15L33 (4)	15L33 (5)
	Impeller / Diffuser Package - High Flow		15L34 (3)	15L34 (4)	15L34 (5)

Old Pump had a single mechanical seal and the capacitor was located outside the pump.

New Pump has a dual mechanical seal and the capacitor is located inside the pump (except ½ HP, 1/60/115 V model).

**MODEL 3885 - WE SERIES**

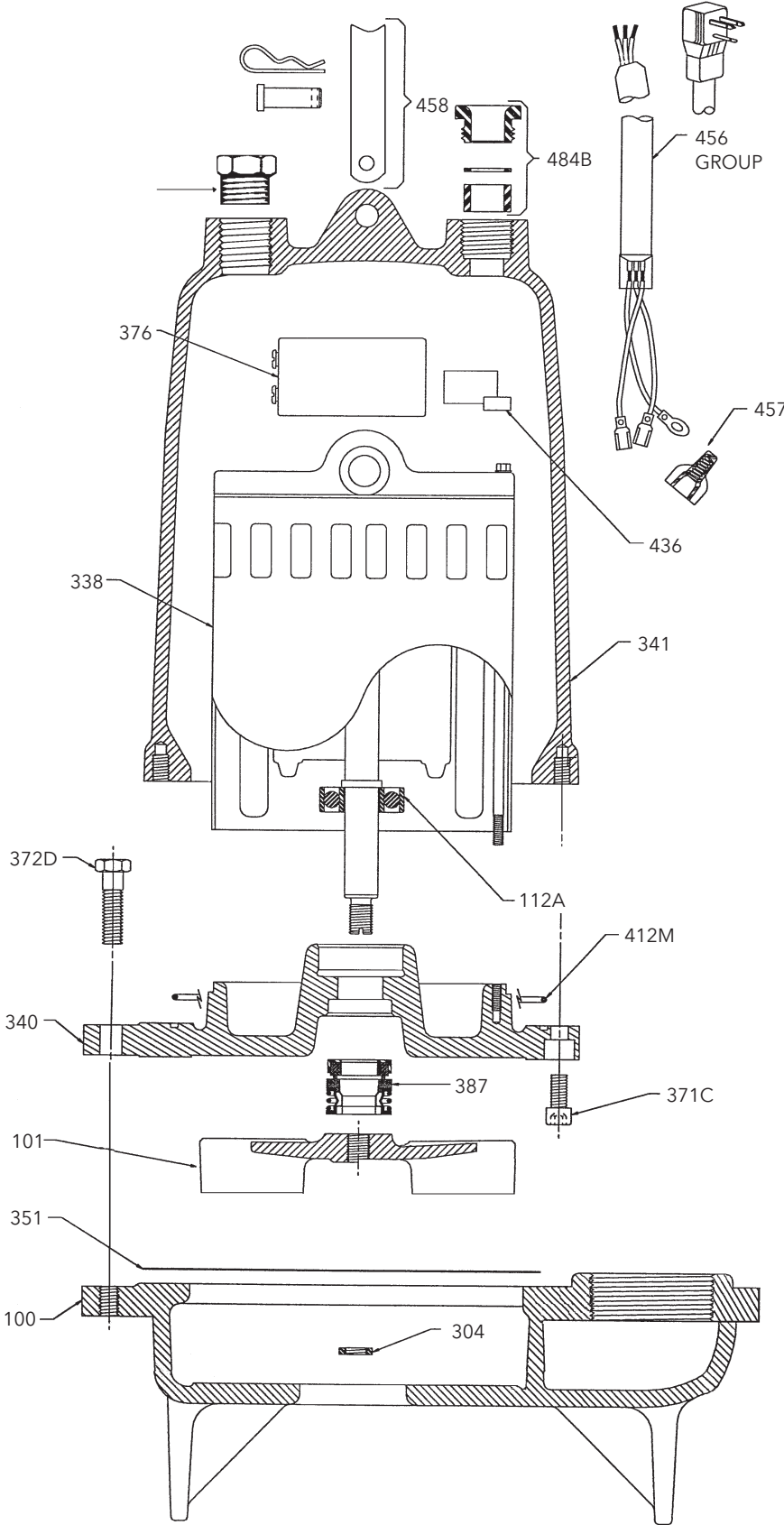

CAPACITOR DATA		
"K" no.	MFD	VAC
9K197	161/193	110
9K351	30	370
9K352	200/240	220

### MODEL 3885 - WE SERIES

Item No.	Part Description	Material	Qty. Req'd.	Repair Parts Order Number						Max. Wt. (lbs.)
				1725 RPM		3450 RPM				
				½ HP	½ HP	¾ HP	1 HP	1½ HP	2 HP	
100	Casing - ½ HP "L" Model Only 59115	Cast Iron	1	1K171	N/A					13.0
	Casing - All Others (M, H, HH) 59114			1K170						
101	Impeller	Cast Iron	1	2K158	2K220	2K219	2K218	2K217	2K840	2.0
	Impeller	Bronze		2K271	2K272	2K273	2K274	2K275	2K841	2½
	Impeller - High Head "HH"	Cast Iron		N/A	2K225	N/A	N/A	2K221	N/A	3½
	Impeller - High Head "HH"	Bronze		N/A	2K276	N/A	N/A	2K277	N/A	4.0
112A	Lower Ball Bearing	Steel	1	4K132					4K384	-
112B	Upper Ball Bearing	Steel	1	4K132						-
218	Insulating Turbine Oil	ASTM150		4K432 (1 gallon ½-1½ HP, .88 gallons 2 HP)						7½ lbs./gal.
304	Impeller Locknut - All	AISI 300 SS	1	13K286						-
338	Motor	Motor with Stainless Steel Shaft	1	118-121R	118-1222R	N/A	N/A	N/A	N/A	13.0 to 24.0
				118-1215R	118-1236R	118-1236R	118-1238R	118-1238R	N/A	
				118-122R	118-1223R	118-1232R	118-1233R	118-1234R	120-845R	
				N/A	118-1333R	118-1334R	118-1335R	118-1336R	120-8425R	
				N/A	118-1321R	118-1322R	118-1323R	118-1324R	120-8425R	
				N/A	118-1328R	118-1330R	118-1330R	118-1331R	120-8435R	
340	Seal / Bearing Housing	Cast Iron	1	1K167					1K332	10.0
341	Motor Cover	Cast Iron	1	1K207			1K208			23.0
				N/A	1K208					
351	Casing Gasket - All Except "HH"		Composite	1	5K170					-
	Shim Set - "HH" Models Only		Plastic	1	5K169					-
358E	Plug - Motor Cover ¾" NPT		AISI 300 SS	1	6K169					-
371C	Skt. Hd. Screw - Housing to Motor Cover		AISI 300 SS	4	13K271					-
372D	Hex Cap Screw - Housing to Casing		AISI 300 SS	4	13K186					-
376	Capacitor (1 Phase Only)	Varies	1	9K197				9K352	-	
				N/A				9K351		
387	Mechanical Seal - Standard		Silicon Carbide	1	10K120			10K119	-	
	Mechanical Seal - Optional		Tungsten Carbide	1	10K122			10K123	-	
412M	O-ring - Motor Cover		BUNA-N, AS568A-166	1	4K252					-
436	Motor Start Switch (1 Phase Only)			1	629002-2				9K356	-
457	Wire Nut (Power Cable)	Special Nylon Housing	2 up to 6	N/A				9K145	-	
				N/A	9K145					
458	Handle Assembly		AISI 300 SS	1	4K243					-
484B	Strain Relief Assembly (Power Cable)	Varies	1	5K113			5K111		-	
				1	N/A	5K111				-
	Loctite #271 - Impeller / Nut			1	AL27121					-

Item No. 456, Power Cables	Type and AWG Size	Standard length	Optional Lengths				Wt. (lbs./5 ft.)
		20'	30'	50'	100'		
1 PH: ½ HP, 115 V; standard with plug, optional length cords have bare leads.	SJTOW - 16/3	9K165	9K214	9K215	N/A	0.5	
1 PH: ½ HP, 115 V; standard with plug, optional length cords have bare leads.	STOW - 14/3	9K385 - SJTOW	9K216*	9K161*	9K217*	0.9	
1 PH: ¾ & 1 HP, 208 & 230 V; standard with plug, opt. length cords have bare leads.	SJTOW - 16/3	9K164	9K214	9K215	N/A	0.5	
1 PH: ¾ & 1 HP, 208 & 230 V; standard with plug, opt. length cords have bare leads.	STOW - 14/3	9K444 - SJTOW	9K216*	9K161*	9K217*	0.9	
1 PH: 1½ HP, 208 & 230 V with bare leads.	STOW - 14/3	9K163	9K216*	9K161*	9K217*	0.9	
1 PH: 2 HP, 230 V with bare leads.	STOW - 14/3	9K266	9K267	9K268	9K269	0.9	
3 PH: ½ - 2 HP, 200-230/460/575 V with bare leads.	STOW - 14/4	9K153	9K218	9K154	9K219	1.1	

\* Requires 5K111 Strain Relief Assembly and 1K208 Motor Cover.  
 "P" option -9K445 1PH, 208/230 V, 14/3 SJTOW Cord with Plug, 30 ft.

### MODEL 2ED

CAPACITOR DATA		
"K" no.	MFD	VAC
9K197	161/193	110

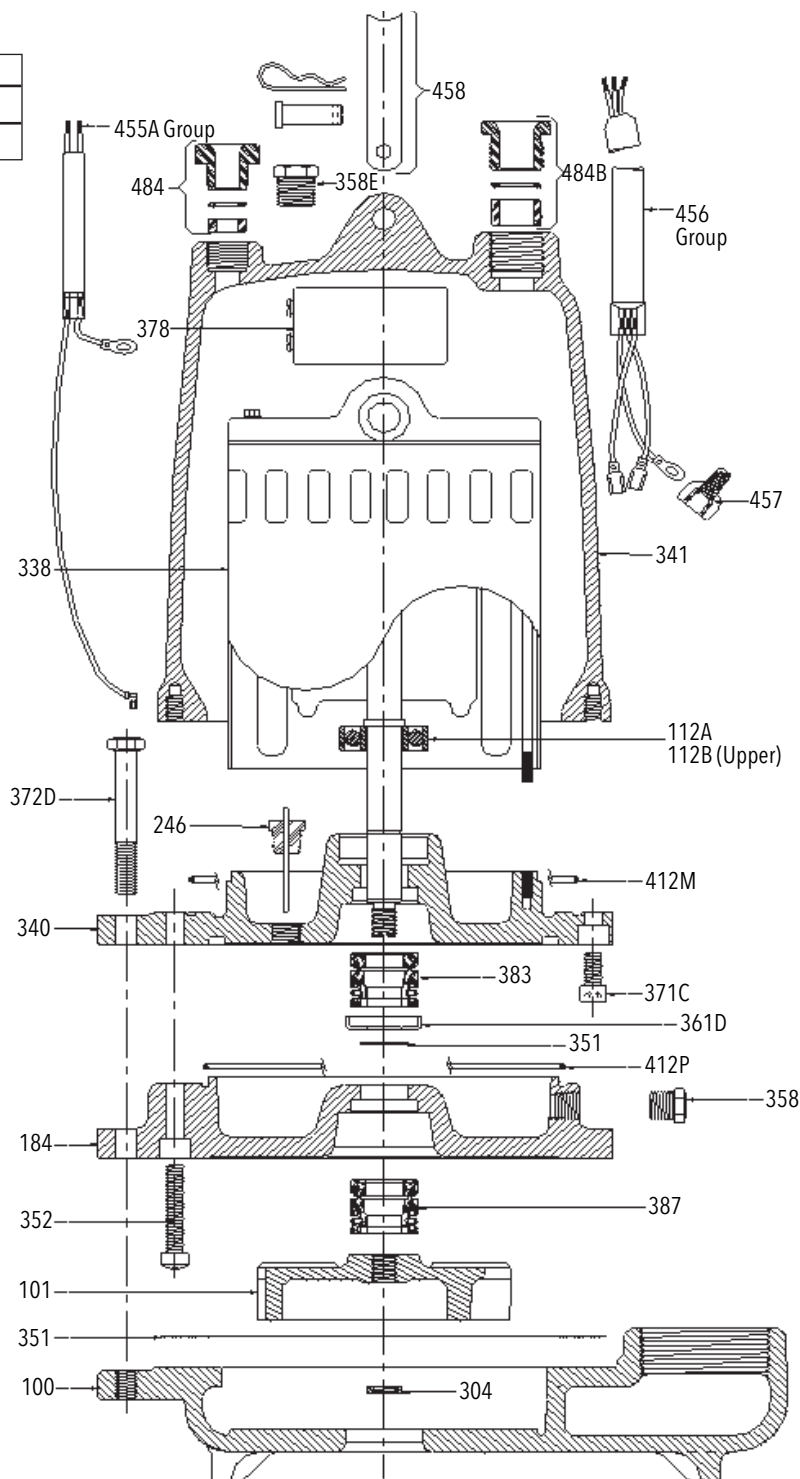

Item No. 456, Power Cables	Type and AWG Size	Standard length				Wt. (lbs./5 ft.)
		20'	30'	50'	100'	
1 PH: 1/3 HP, 115 V; standard with plug, optional lengths have bare leads.	SJTOW - 16/3	9K165	9K214	9K215	N/A	0.5
1 PH: 1/2 HP, 115 V; standard with plug, optional lengths have bare leads.	STOW - 14/3	9K385 - SJTOW	9K216*	9K161*	9K217*	0.9
1 PH: 1/3 & 1/2 HP, 208 & 230 V; standard with plug, opt. lengths have bare leads.	SJTOW - 16/3	9K164	9K214	9K215	N/A	0.5
1 PH: 3/4 - 1 1/2 HP, 208 & 230 V with bare leads.	STOW - 14/3	9K163	9K216	9K161	9K217	0.9
3 PH: 1/2 - 1 1/2 HP, 200-230/460/575 V with bare leads.	STOW - 14/4	9K153	9K218	9K154	9K219	1.1
<b>Item No. 455A, Sensor Cables</b>						
Mechanical Seal Sensor - Standard for All Models	SJTOW - 16/2	9K189	9K220	9K221	9K222	0.5
Mechanical Seal/Heat Sensor - Optional for 3-Phase Models	SJTOW - 18/4	9K237	9K238	9K239	9K240	0.5

\* Requires 5K111 Strain Relief Assembly and 1K208 Motor Cover.



### MODEL 2ED (Dual Seal)

Item No.	Part Description	Material	Qty. Req'd.	Repair Parts Order Number					Max. Wt. (lbs.)
				1725 RPM	3450 RPM				
				1/2 HP	1/2 HP	3/4 HP	1 HP	1 1/2 HP	
100	Casing - "F" Model Only (8th Digit)	Cast Iron	1	1K171	N/A				13.0
	Casing - All Others			N/A	1K170				
101	Impeller - Standard	Cast Iron	1	2K158 E, F = 5 3/8"	2K220 D = 3 1/16"	2K219 C = 4 1/16"	2K218 B = 4 7/16"	2K217 A = 4 7/16"	4.0
	Model Number (8th Digit) = Diameter	Bronze		2K271 E, F = 5 3/8"	2K272 D = 3 1/16"	2K273 C = 4 1/16"	2K274 B = 4 7/16"	2K275 A = 4 7/16"	2.5
	Impeller - High Head	Cast Iron		N/A	2K225 H = 3 3/8"	N/A	N/A	2K221 G = 5 1/2"	3.5
	Model Number (8th Digit) = Diameter	Bronze		N/A	2K276 H = 3 3/8"	N/A	N/A	2K277 G = 5 1/2"	4.0
	Impeller - High Head								
	Model Number (8th Digit) = Diameter								
112A	Lower Ball Bearing	Steel	1	4K132				-	
112B	Upper Ball Bearing	Steel	1	4K132				-	
184	Seal Housing	Cast Iron	1	1K229				9.5	
218	Insulating Oil - Gallons Required	Turbine Oil - ASTM150	-	4K432				7 1/2 lbs./gal.	
	Gallons Required in Seal Housing			0.10					
	Gallons Required in Motor Cover			1.0					
246	Seal Sensor - Plug and Rod	Nylon/Brass	1	9K191				-	
304	Impeller Locknut - All	AISI 300 SS	1	13K286				-	
338	Motor	Stainless Steel Shaft	1	119-493R	119-4931R	N/A			13.0 to 24.0
				119-49815R	119-4992R	119-4992R	119-4994R	119-4994R	
				119-494R	119-4932R	119-4934R	119-4934R	119-4935R	
				N/A	119-4971R	119-4973R	119-4973R	119-4974R	
				N/A	119-4941R	119-4943R	119-4943R	119-4944R	
				N/A	119-4951R	119-4954R	119-4954R	119-4954R	
340	Bearing Housing	Cast Iron	1	1K228				10.0	
341	Motor Cover	Cast Iron	1	1K230		1K231			23.0
				N/A	1K231				
351	Casing Gasket	Composite	1	5K170				-	
	Shim Set - "High Head" Models Only	Plastic	1	5K169				-	
352	Skt. Hd. Screw - Seal Housing to Motor Cover	AISI 300 SS	2	13K219				-	
358	Plug - Seal Housing 1/4" NPT	AISI 300 SS	1	6K168				-	
358E	Plug - Motor Cover 3/8" NPT	AISI 300 SS	1	6K169				-	
361	Retaining Ring	AISI 300 SS	1	4K375				-	
361D	Seal Retainer	AISI 300 SS	1	4K379				-	
371C	Skt. Hd. Screw - Bearing Housing to Motor Cover	AISI 300 SS	2	13K271				-	
372D	Hex Cap Screw - Housing to Casing	AISI 300 SS	4	13K222				-	
376	Capacitor (1 Phase Only) - Start	-	1	9K197				-	
383	Mechanical Seal - Upper	Carbon/Ceramic	1	10K121 (Type 16)				-	
387	Mechanical Seal - Lower (Standard)	Silicon Carbon	1	10K120 (Type 16)				-	
	Mechanical Seal - Lower (Optional)	Tungsten Carbon	1	10K122 (Type 16)				-	
412M	O-ring - Motor Cover	BUNA-N, AS 568A-166	1	4K252				-	
412P	O-ring - Seal/Bearing Housing	BUNA-N, AS 568A-163	1	5K181				-	
457	Wire Nut	Special Nylon Housing	N/A	None Required				-	
			1 pkg.	N/A	9K145 (package of 8)			-	
			1 pkg.	9K145 (package of 8)				-	
458	Handle Assembly	AISI 300 SS	1	4K243				-	
484	Strain Relief Assembly, Sensor Cable	Varies	1	5K113				-	
484B	Strain Relief Assembly (Power Cable)	Varies	1	5K113		5K111		-	
			1	N/A	5K111			-	
	Heat Sensor Kit (Optional)	-	1	9K261				-	
	Seal Installation Tool	-	1	A02A013				-	
	Loctite #271	-	1	AL27121				-	

### MODELS 3886, 3887 (WS\_B, WS\_BF, WS\_BHF)

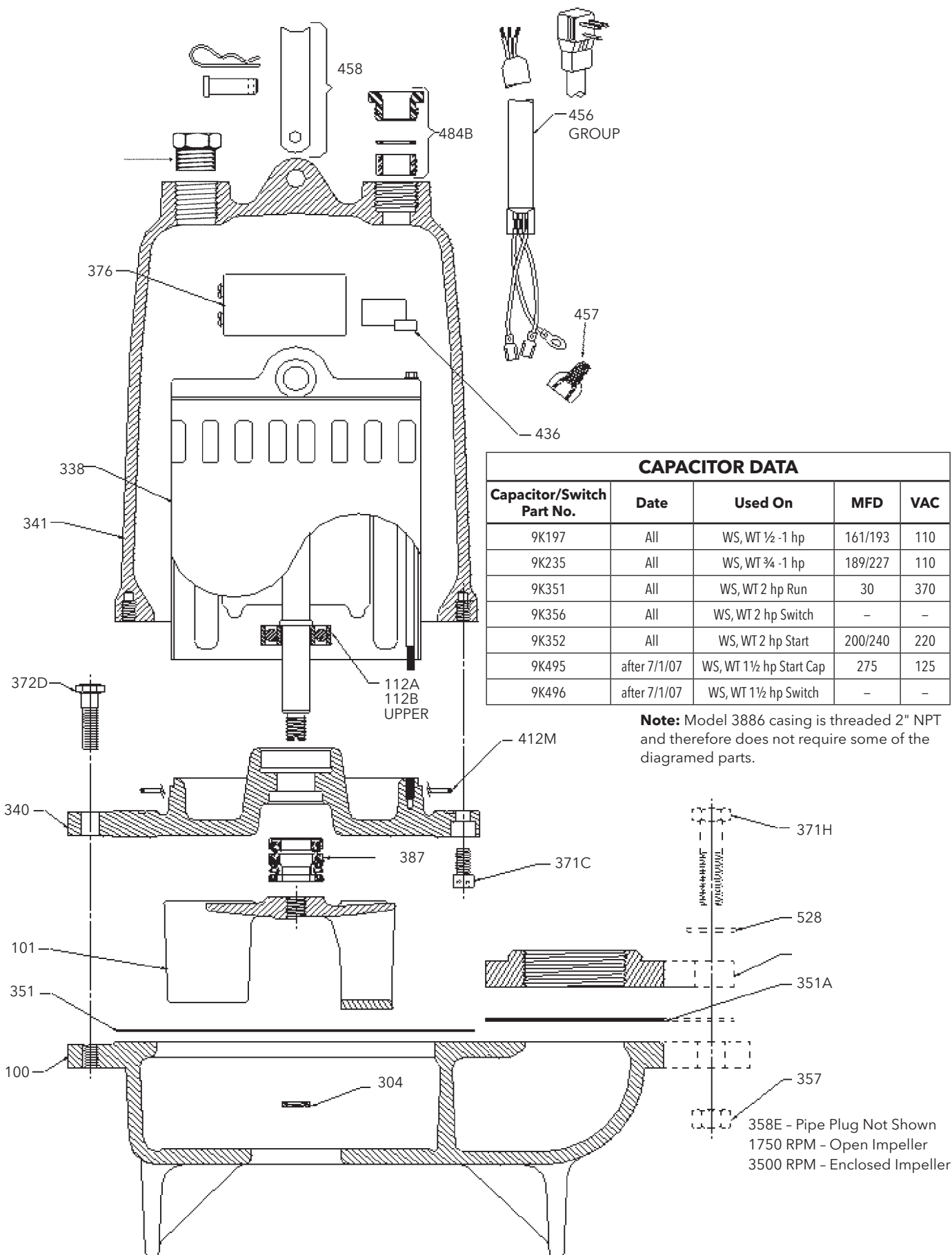

### MODEL 3886 (WS\_B)

Item No.	Part Description	Material	Qty. Req.	Repair Parts Order Number				Max. Wt. (lbs.)
				1725 RPM				
				1/3 HP	1/2 HP	3/4 HP	1 HP	
100	Casing	Cast Iron	1	1K168				16.5
101	Impeller	Cast Iron	1	2K268	2K239	2K240	2K241	3.0
	Impeller	Bronze	1	2K279	2K280	2K281	2K282	3.5
112A	Lower Ball Bearing	Steel	1	4K132				-
112B	Upper Ball Bearing	Steel	1	4K132				-
218	Insulating Turbine Oil	ASTM150	-	4K432 (1 gallon 1/3 - 1 HP)				7.5 lbs./gal.
304	Impeller Locknut - All	AISI 300 SS	1	13K286				-
338	Motor - 1 Phase, 115V	Motor with Stainless Steel Shaft	1	118-121R	118-123R	N/A	N/A	13.0 to 24.0
	Motor - 1 Phase, 208V			118-1215R	118-1215R	118-1217R	118-1217R	
	Motor - 1 Phase, 230V			118-122R	118-124R	118-1212R	118-1213R	
	Motor - 3 Phase, 200 V			N/A	118-1314R	118-1316R	118-1316R	
	Motor - 3 Phase, 230/460 V			N/A	118-132R	118-134R	118-134R	
	Motor - 3 Phase, 575 V			N/A	118-139R	118-1311R	118-1311R	
340	Seal / Bearing Housing	Cast Iron	1	1K167				10.0
341	Motor Cover - 1 Phase	Cast Iron	1	1K207				20.0
	Motor Cover - 3 Phase			1K208				
351	Casing Gasket	Composite	1	5K170				-
358E	Plug - Motor Cover 3/8" NPT	AISI 300 SS	1	6K169				-
371C	Skt. Hd. Screw - Housing to Motor Cover	AISI 300 SS	4	13K271				-
372D	Hex Cap Screw - Housing to Casing	AISI 300 SS	4	13K186				-
376	Capacitor (1 Phase only) Start	Varies	1	9K197		9K235		-
387	Mechanical Seal - Standard	Silicon Carbide	1	10K120				-
	Mechanical Seal - Optional	Tungsten Carbide	1	10K122				-
412M	O-ring - Motor Cover	BUNA-N, A5568A-166	1	4K252				-
457	Wire Nut (Power Cable)	1 Phase	-	N/A				-
		3 Phase	upto 6	N/A	9K145			-
458	Handle Assembly	AISI 300 SS	1	4K243				-
484B	Strain Relief Assembly (Power Cable)	1 Phase	1	5K113				-
		3 Phase	1	N/A	5K111			-
	Loctite #271	-	1	AL27121				-

Item No. 456, Power Cables	Type and AWG Size	Standard length	Optional Lengths			Wt. (lbs./5 ft.)
		20'	30'	50'	100'	
1 PH: 1/3 HP, 115 V; standard with plug, optional length cords have bare leads.	SJTOW - 16/3	9K165	9K214	9K215	N/A	0.5
1 PH: 1/2 HP, 115 V; standard with plug, optional length cords have bare leads.	STOW - 14/3	9K385 - SJTOW	9K216*	9K161*	9K217*	0.9
1 PH: 1/3 and 1/2 HP, 208 & 230 V; standard with plug, opt. length cords have bare leads.	SJTOW - 16/3	9K164	9K214	9K215	N/A	0.5
1 PH: 3/4 & 1 HP, 208 & 230 V; standard with plug, opt. length cords have bare leads.	STOW - 14/3	9K444 - SJTOW	9K216*	9K161*	9K217*	0.9
3 PH: 1/2 - 1 HP, 200-230/460/575 V with bare leads.	STOW - 14/4	9K153	9K218	9K154	9K219	1.1

\* Requires 5K111 Strain Relief Assembly and 1K208 Motor Cover.

"P" option -9K445 1PH, 208/230 V, 14/3 SJTOW Cord with Plug, 30 ft.

### MODEL 3887 (WS\_BF)

Item No.	Part Description	Material	Qty. Req.	Repair Parts Order Number				Max. Wt. (lbs.)
				1725 RPM				
				1/3 HP	1/2 HP	3/4 HP	1 HP	
100	Casing	Cast Iron	1	1K178				16.5
101	Impeller	Cast Iron	1	2K268	2K239	2K240	2K241	3.0
	Impeller	Bronze	1	2K279	2K280	2K281	2K282	3.5
112A	Lower Ball Bearing	Steel	1	4K132				-
112B	Upper Ball Bearing	Steel	1	4K132				-
195C	Discharge Flange (2" NPT STD.)	Cast Iron	1	6K76				1.5
	Discharge Flange (3" NPT OPT.)			A1-3				
218	Insulating Turbine Oil	ASTM150	1	4K432 (1.0 gallons, 1/3 - 1 HP)				7.5 lbs./gal.
304	Impeller Locknut - All	AISI 300 SS	1	13K286				-
338	Motor - 1 Phase, 115V	Motor with Stainless Steel Shaft	1	118-121R	118-123R	N/A	N/A	13.0 to 24.0
	Motor - 1 Phase, 208V			118-1215R	118-1215R	118-1217R	118-1217R	
	Motor - 1 Phase, 230V			118-122R	118-124R	118-1212R	118-1213R	
	Motor - 3 Phase, 200 V			N/A	118-1314R	118-1316R	118-1316R	
	Motor - 3 Phase, 230/460 V			N/A	118-132R	118-134R	118-134R	
	Motor - 3 Phase, 575 V			N/A	118-139R	118-1311R	118-1311R	
340	Seal / Bearing Housing	Cast Iron	1	1K167				10.0
341	Motor Cover - 1 Phase	Cast Iron	1	1K207				20.0
	Motor Cover - 3 Phase			1K208				
351	Casing Gasket	Composite	1	5K170				-
351A	Discharge Flange Gasket	Composite	1	5K150				-
357	Hex Nut - Discharge Flange	AISI 300 SS	2	13K99				-
358E	Plug - Motor Cover 3/8" NPT	AISI 300 SS	1	6K169				-
371C	Skt. Hd. Screw - Housing to Motor Cover	AISI 300 SS	4	13K271				-
371H	Hex Cap Screw - Discharge Flange	AISI 300 SS	2	13K153				-
372D	Hex Screw - Housing to Casing	AISI 300 SS	4	13K186				-
376	Capacitor (1 Phase Only) Start	Varies	1	9K197		9K235		-
387	Mechanical Seal - Standard	Silicon Carbide	1	10K120				-
	Mechanical Seal - Optional	Tungsten Carbide	1	10K122				-
412M	O-Ring - Motor Cover	Buna-N, AS 568A-166	1	4K252				-
457	Wire Nut, Power Cable, 3 Phase	Special Nylon Housing	Up to 6	N/A	9K145		-	
458	Handle Assembly	AISI 300 SS	1	4K243				-
484B	Strain Relief Assembly (Power Cable)	1 PH	1	5K113				-
		3 PH		N/A	5K111			
528	Washer - Discharge Flange	AISI 300 SS	2	13K82				-
	Loctite #271	-	1	AL27121				-

Item No. 456, Power Cables	Type and AWG Size	Standard length	Optional Lengths			Wt. (lbs./5 ft.)
		20'	30'	50'	100'	
1 PH: 1/3 HP, 115 V; standard with plug, optional length cords have bare leads.	SJTOW - 16/3	9K165	9K214	9K215	N/A	0.5
1 PH: 1/2 HP, 115 V; standard with plug, optional length cords have bare leads.	STOW - 14/3	9K385 - SJTOW	9K216*	9K161*	9K217*	0.9
1 PH: 1/3 & 1/2 HP, 208 & 230 V; standard with plug, optional length cords have bare leads.	SJTOW - 16/3	9K164	9K214	9K215	N/A	0.5
1 PH: 3/4 & 1 HP, 208 & 230 V; standard with plug, optional length cords have bare leads.	STOW - 14/3	9K444 - SJTOW	9K216*	9K161*	9K217*	0.9
3 PH: 1/2 - 1 HP, 200-230/460/575 V with bare leads.	STOW - 14/4	9K153	9K218	9K154	9K219	1.1

\* Requires 5K111 Strain Relief Assembly and 1K208 Motor Cover.  
 "P" option -9K445 1PH, 208/230 V, 14/3 SJTOW Cord with Plug, 30 ft.

### MODEL 3887 (WS\_BHF)

Item No.	Part Description	Material	Qty. Req.	Repair Parts Order Number						Max. Wt. (lbs.)
				3450 RPM						
				1/2 HP	1/2 HP	3/4 HP	1 HP	1 1/2 HP	2 HP	
100	Casing	Cast Iron	1	1K330						16.5
101	Impeller	Cast Iron	1	2K858	2K856	2K854	2K852	2K800	2K798	3.0
	Impeller	Bronze	1	2K859	2K857	2K855	2K853	2K801	2K799	3.5
112A	Lower Ball Bearing	Steel	1	4K132			4K384			-
112B	Upper Ball Bearing	Steel	1	4K132						-
195C	Discharge Flange (2" NPT STD.)	Cast Iron	1	6K76						1.5
	Discharge Flange (3" NPT OPT.)	Cast Iron	1	A1-3						1.5
218	Insulating Turbine Oil	ASTM150	-	4K432 (1 gallon 1/2-1 HP, .88 gallons 1 1/2 and 2 HP)						7.5 lbs./gal.
304	Impeller Locknut - All	AISI 300 SS	1	13K286						-
338	Motor - 1 Phase, 115V	Stainless Steel Shaft	1	118-1222R	118-1222R	N/A	N/A	N/A	N/A	13.0 to 24.0
	Motor - 1 Phase, 208V			118-1236R	118-1236R	118-1236R	118-1238R	N/A	N/A	
	Motor - 1 Phase, 230V			118-1223R	118-1223R	118-1232R	118-1233R	120-844R	120-845R	
	Motor - 3 Phase, 200 V			N/A	118-1333R	118-1334R	118-1335R	120-8425R	120-8425R	
	Motor - 3 Phase, 230/460 V			N/A	118-1321R	118-1322R	118-1323R	120-8425R	120-8425R	
	Motor - 3 Phase, 575 V			N/A	118-1328R	118-1330R	118-1330R	120-8435R	120-8435R	
340	Seal / Bearing Housing	Cast Iron	1	1K167			1K332			10.0
341	Motor Cover - 1 Phase	Cast Iron	1	1K207			1K208			20.0
	Motor Cover - 3 Phase			1K208						
351	Casing Gasket	Composite	1	5K170						-
351A	Discharge Flange Gasket	Composite	1	5K150						-
357	Hex Nut - Discharge Flange	AISI 300 SS	2	13K99						-
358E	Plug - Motor Cover 3/8" NPT	AISI 300 SS	1	6K169						-
371C	Skt. Hd. Screw - Housing to Motor Cover	AISI 300 SS	4	13K271						-
371H	Hex Cap Screw - Discharge Flange	AISI 300 SS	2	13K153						-
372D	Hex Cap Screw - Housing to Casing	AISI 300 SS	4	13K186						-
387	Mechanical Seal - Standard	Silicon Carbide	1	10K120			10K119			-
	Mechanical Seal - Optional	Tungsten Carbide	1	10K122			10K123			-
412M	O-Ring - Motor Cover	BUNA-N, AS568A-166	1	4K252						-
457	Wire Nut (Power Cable)	Special Nylon Housing	2	N/A			9K145			-
				upto 6	N/A	9K145				-
458	Handle Assembly	AISI 300 SS	1	4K243						-
484B	Strain Relief Assembly (Power Cable)	Varies	1	5K113			5K111			-
				N/A	5K111					
528	Washer - Discharge Flange	AISI 300 SS	2	13K82						-
	Loctite #271	-	1	AL27121						-

Item No. 456, Power Cables	Type and AWG Size	Standard length	Optional Lengths			Wt. (lbs./5 ft.)
		20'	30'	50'	100'	
1 PH: 1/2 HP, 115 V; standard with plug, optional lengths have bare leads.	SJTOW - 16/3	9K165	9K214	9K215	N/A	0.5
1 PH: 1/2 HP, 115 V; standard with plug, optional lengths have bare leads.	STOW - 14/3	9K385 - SJTOW	9K216*	9K161*	9K217*	0.9
1 PH: 1/3 and 1/2 HP, 208 & 230 V; standard with plug, optional lengths have bare leads.	SJTOW - 16/3	9K164	9K214	9K215	N/A	0.5
1 PH: 3/4 - 1 HP, 208 & 230 V; standard with plug, optional lengths have bare leads.	STOW - 14/3	9K444 - SJTOW	9K216*	9K161*	9K217*	0.9
1 PH: 1 1/2 and 2 HP, 230 V with bare leads.	STOW - 14/3	9K266	9K267	9K268	9K269	0.9
3 PH: 1/2 - 2 HP, 200-230/460/575 V with bare leads.	STOW - 14/4	9K153	9K218	9K154	9K219	1.1

\* Requires 5K111 Strain Relief Assembly and 1K208 Motor Cover.  
 "P" option -9K445 1PH, 208/230 V, 14/3 SJTOW Cord with Plug, 30 ft.

### MODEL 2WD/3WD

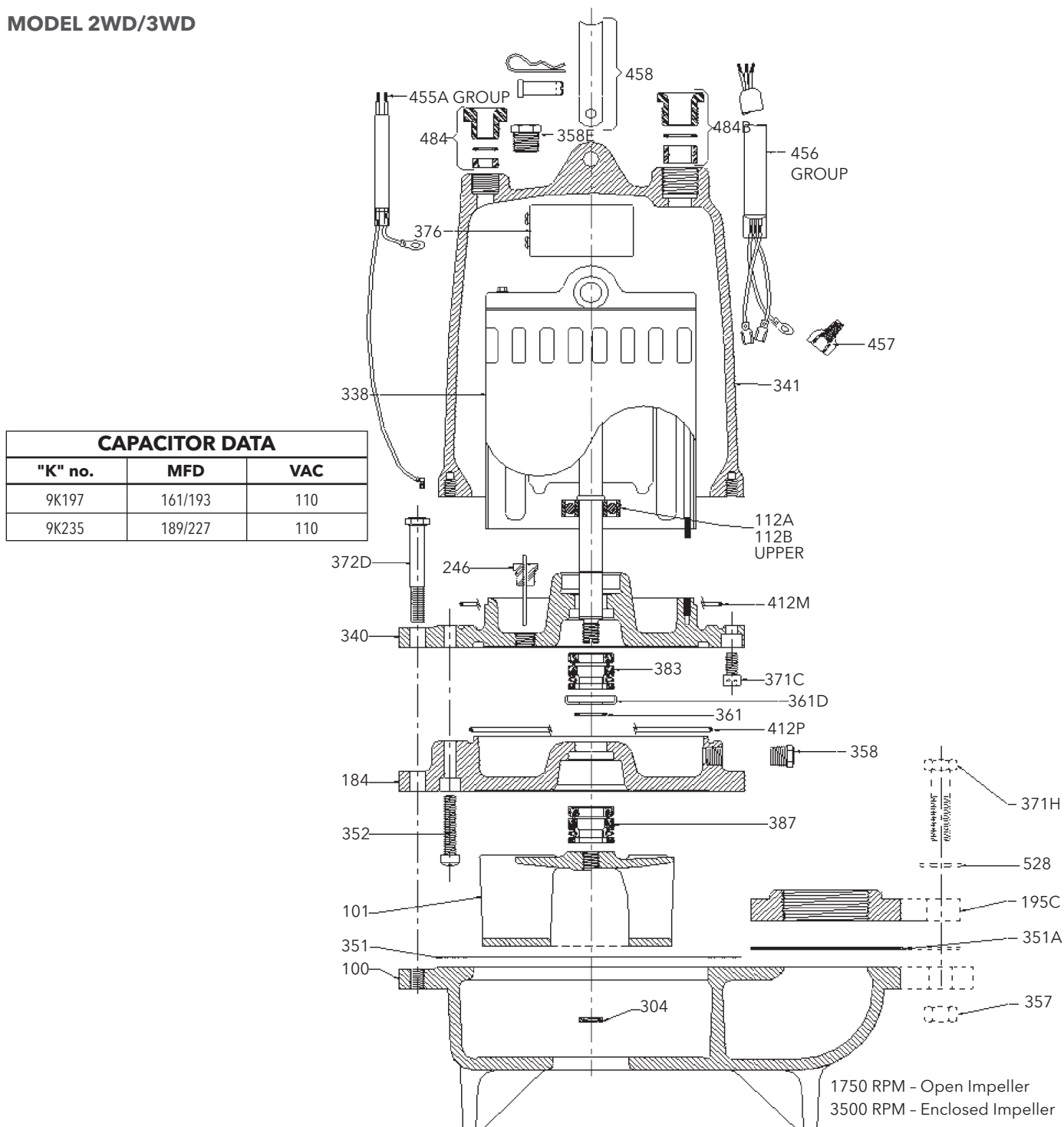

#### CAPACITOR DATA

"K" no.	MFD	VAC
9K197	161/193	110
9K235	189/227	110

Item No. 456, Power Cables	Type and AWG Size	Standard length				Wt. (lbs./5 ft.)
		20'	30'	50'	100'	
1 PH: 1/3 HP, 115 V; standard with plug, optional lengths have bare leads.	SJTOW - 16/3	9K165	9K214	9K215	N/A	0.5
1 PH: 1/2 HP, 115 V; standard with plug, optional lengths have bare leads.	STOW - 14/3	9K385 - SJTOW	9K216*	9K161*	9K217*	0.9
1 PH: 1/3 & 1/2 HP, 208 & 230 V; standard with plug, opt. lengths have bare leads.	SJTOW - 16/3	9K164	9K214	9K215	N/A	0.5
1 PH: 3/4 - 1 HP, 208 & 230 V with bare leads.	STOW - 14/3	9K163	9K216	9K161	9K217	0.9
3 PH: 1/2 - 1 HP, 200-230/460/575 V with bare leads.	STOW - 14/4	9K153	9K218	9K154	9K219	1.1
<b>Item No. 455A, Sensor Cables</b>						
Mechanical Seal Sensor - Standard for All Models	SJTOW - 16/2	9K189	9K220	9K221	9K222	0.5
Mechanical Seal/Heat Sensor - Optional for 3-Phase Models	SJTOW - 18/4	9K237	9K238	9K239	9K240	0.5

\* Requires 5K111 Strain Relief Assembly and 1K208 Motor Cover.

### MODEL 2WD/3WD (1725 RPM)

Item No.	Part Description	Material	Qty. Req.	Repair Parts Order Number				Max. Wt. (lbs.)
				1725 RPM				
				1/3 HP	1/2 HP	3/4 HP	1 HP	
100	Casing	Cast Iron	1	1K178				16.5
101	Impeller	Cast Iron	1	2K268 E = 4 <sup>11</sup> / <sub>16</sub> "	2K239 D = 5"	2K240 C = 5 <sup>3</sup> / <sub>8</sub> "	2K241 B = 5 <sup>3</sup> / <sub>4</sub> "	3.0
	Impeller	Bronze	1	2K279 E = 4 <sup>11</sup> / <sub>16</sub> "	2K280 D = 5"	2K281 C = 5 <sup>3</sup> / <sub>8</sub> "	2K282 B = 5 <sup>3</sup> / <sub>4</sub> "	3.5
112A	Lower Ball Bearing	Steel	1	4K132				-
112B	Upper Ball Bearing	Steel	1	4K132				-
184	Seal Housing	Cast Iron	1	1K229				9.5
195C	Discharge Flange - Standard 2" NPT	Cast Iron	1	6K76				1.5
	Discharge Flange - Optional 3" NPT			A1-3				
218	Insulating Oil - Gallons Required	Turbine Oil - ASTM150	-	4K432				7.5 lbs./gal.
	Gallons Required in Seal Housing			0.10				
	Gallons Required in Motor Cover			1.0				
246	Seal Sensor - Plug and Rod	Nylon/Brass	1	9K198				-
304	Impeller Locknut - All	AISI 300 SS	1	13K286				-
338	Motor - 1 Phase, 115V	Stainless Steel Shaft	1	119-493R	119-493R	N/A	N/A	13.0 to 24.0
	Motor - 1 Phase, 208V			119-4981R	119-4981R	119-4983R	119-4983R	
	Motor - 1 Phase, 230V			119-494R	119-494R	119-496R	119-496R	
	Motor - 3 Phase, 200V			N/A	119-4961R	119-4963R	119-4963R	
	Motor - 3 Phase, 230/460V			N/A	119-4911R	119-4913R	119-4913R	
	Motor - 3 Phase, 575V			N/A	119-4921R	119-4923R	119-4923R	
340	Bearing Housing	Cast Iron	1	1K228				10.0
341	Motor Cover - 1 Phase	Cast Iron	1	1K230		1K231		20.0
	Motor Cover - 3 Phase			1K231				
351	Casing Gasket	Composite	1	5K170				-
351A	Discharge Flange Gasket	Composite	1	5K150				-
352	Skt. Hd. Screw - Seal Hsg. to Motor Cover	AISI 300 SS	2	13K219				-
357	Hex Nut - Discharge Flange	AISI 300 SS	2	13K99				-
358	Plug - Seal Housing 1/4" NPT	AISI 300 SS	1	6K168				-
358E	Plug - Motor Cover 3/8" NPT	AISI 300 SS	1	6K169				-
361	Retaining Ring	AISI 300 SS	1	4K375				-
361D	Seal Retainer	AISI 300 SS	1	4K379				-
371C	Skt. Hd. Screw - Brg. Hsg. to Motor Cover	AISI 300 SS	2	13K271				-
371H	Hex Cap Screw - Discharge Flange	AISI 300 SS	2	13K153				-
372D	Hex Cap Screw - Housing to Casing	AISI 300 SS	4	13K222				-
376	Capacitor (1 Phase only) - Start	Varies	1	9K197		9K235		-
383	Mechanical Seal - Upper	Carbon/Ceramic	1	10K121 (Type 16)				-
387	Mechanical Seal - Lower (Standard)	Silicon Carbide	1	10K120 (Type 16)				-
	Mechanical Seal - Lower (Optional)	Tungsten Carbide	1	10K122 (Type 16)				-
412M	O-ring - Motor Cover	BUNA-N, AS568A-166	1	4K252				-
412P	O-ring - Seal/Bearing Housing	BUNA-N, AS568A-163	1	5K181				-
457	Wire Nut	Power Cable - 3 Ph., 460V	1 pkg.	N/A	9K145 (package of 8)			-
		Seal/Heat Cable - Opt. 3 Ph. Only	1 pkg.	9K145 (package of 8)				-
458	Handle Assembly	AISI 300 SS	1	4K243				-
484	Strain Relief Assembly, Sensor Cable	Varies	1	5K113				-
484B	Strain Relief Assembly (Power Cable)	1 Phase	1	5K113		5K111		-
		3 Phase		N/A	5K111			
528	Washer - Discharge Flange	AISI 300 SS	2	13K82				-
-	Heat Sensor Kit (Optional)	-	1	9K261				-
-	Seal Installation Tool	-	1	A02A013				-
-	Loctite #271	-	1	AL27121				-

### MODEL 2WD/3WD

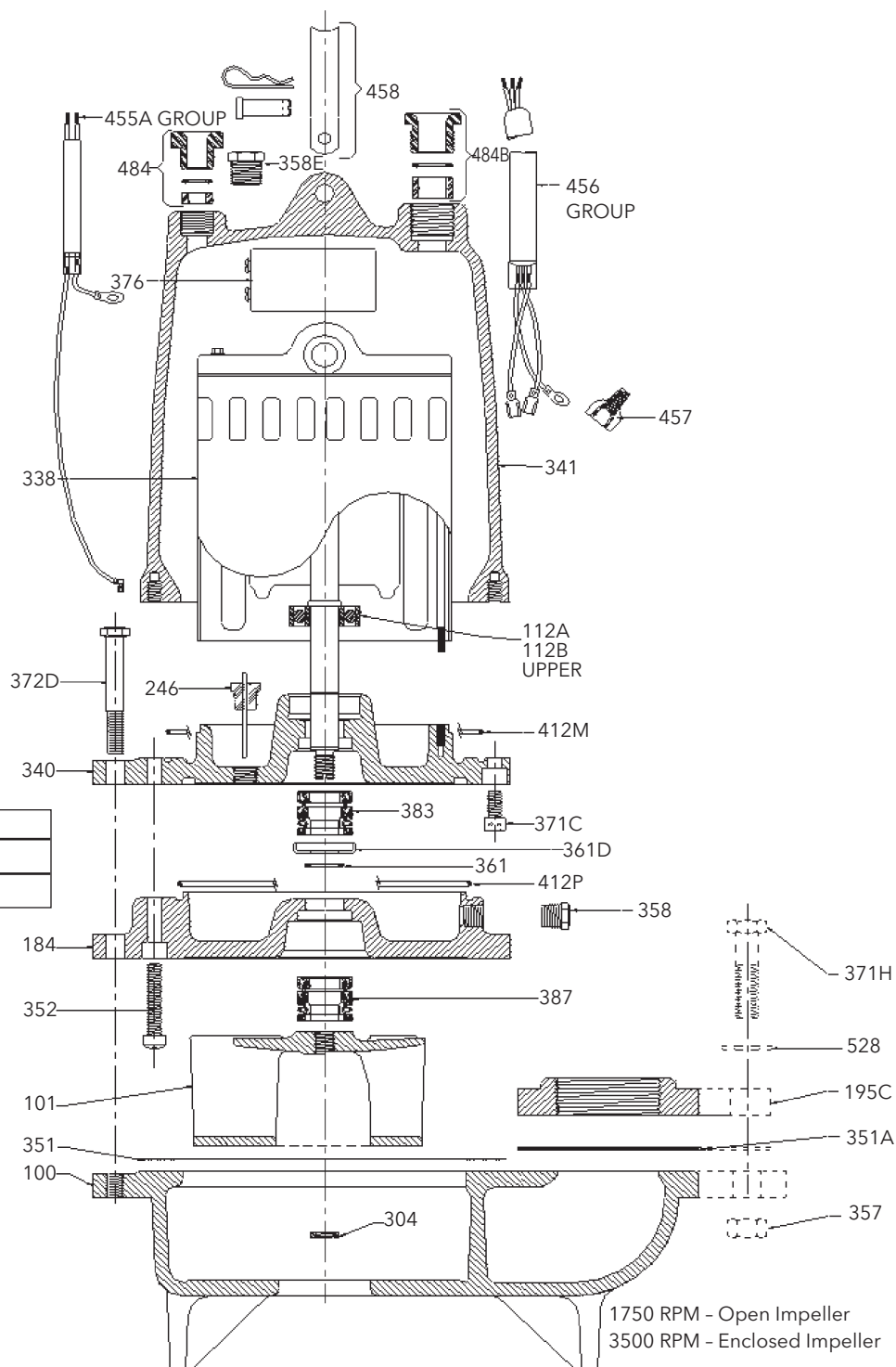

#### CAPACITOR DATA

"K" no.	MFD	VAC
9K197	161/193	110

Item No. 456, Power Cables	Type and AWG Size	Standard length				Wt. (lbs./5 ft.)
		20'	30'	50'	100'	
1 PH: 1/3 HP, 115 V; standard with plug, optional lengths have bare leads.	SJTOW - 16/3	9K165	9K214	9K215	N/A	0.5
1 PH: 1/2 HP, 115 V; standard with plug, optional lengths have bare leads.	STOW - 14/3	9K385 - SJTOW	9K216*	9K161*	9K217*	0.9
1 PH: 1/3 & 1/2 HP, 208 & 230 V; standard with plug, opt. lengths have bare leads.	SJTOW - 16/3	9K164	9K214	9K215	N/A	0.5
1 PH: 3/4 - 1 HP, 208 & 230 V with bare leads.	STOW - 14/3	9K163	9K216	9K161	9K217	0.9
3 PH: 1/2 - 1 HP, 200-230/460/575 V with bare leads.	STOW - 14/4	9K153	9K218	9K154	9K219	1.1
Item No. 455A, Sensor Cables						
Mechanical Seal Sensor - Standard for All Models	SJTOW - 16/2	9K189	9K220	9K221	9K222	0.5
Mechanical Seal/Heat Sensor - Optional for 3-Phase Models	SJTOW - 18/4	9K237	9K238	9K239	9K240	0.5

\* Requires 5K111 Strain Relief Assembly and 1K208 Motor Cover.



### MODEL 2WD/3WD (3500 RPM)

Item No.	Part Description	Material	Qty. Req.	Repair Parts Order Number				Max. Wt. (lbs.)
				3450 RPM				
				1/3 HP	1/2 HP	3/4 HP	1 HP	
100	Casing	Cast Iron	1	1K330				16.5
101	Impeller	Cast Iron	1	2K858 K = 2 <sup>15</sup> / <sub>16</sub> "	2K856 J = 3 <sup>3</sup> / <sub>16</sub> "	2K854 H = 3 <sup>7</sup> / <sub>16</sub> "	2K852 A = 3 <sup>3</sup> / <sub>4</sub> "	3.0
	Impeller	Bronze	1	2K859 E = 2 <sup>19</sup> / <sub>16</sub> "	2K857 J = 3 <sup>3</sup> / <sub>16</sub> "	2K855 H = 3 <sup>7</sup> / <sub>16</sub> "	2K853 A = 3 <sup>3</sup> / <sub>4</sub> "	3.5
112A	Lower Ball Bearing	Steel	1	4K132				-
112B	Upper Ball Bearing	Steel	1	4K132				-
184	Seal Housing	Cast Iron	1	1K229				9.5
195C	Discharge Flange - Standard 2" NPT	Cast Iron	1	6K76				1.5
	Discharge Flange - Optional 3" NPT			A1-3				
218	Insulating Oil - Gallons Required	Turbine Oil - ASTM150	-	4K432				7.5 lbs./gal.
	Gallons Required in Seal Housing			0.10				
	Gallons Required in Motor Cover			1.0				
246	Seal Sensor - Plug and Rod	Nylon/Brass	1	9K191				-
304	Impeller Locknut - All	AISI 300 SS	1	13K286				-
338	Motor - 1 Phase, 115V	Stainless Steel Shaft	1	119-4931R	119-4931R	N/A	N/A	13.0 to 24.0
	Motor - 1 Phase, 208V			119-4992R	119-4992R	119-4992R	119-4994R	
	Motor - 1 Phase, 230V			119-4932R	119-4932R	119-4934R	119-4934R	
	Motor - 3 Phase, 200V			N/A	119-4971R	119-4973R	119-4973R	
	Motor - 3 Phase, 230/460V			N/A	119-4941R	119-4943R	119-4943R	
	Motor - 3 Phase, 575V			N/A	119-4951R	119-4954R	119-4954R	
340	Bearing Housing	Cast Iron	1	1K228				10.0
341	Motor Cover - 1 Phase	Cast Iron	1	1K230		1K231		20.0
	Motor Cover - 3 Phase			1K231				
351	Casing Gasket	Composite	1	5K170				-
351A	Discharge Flange Gasket	Composite	1	5K150				-
352	Skt. Hd. Screw - Seal Hsg. to Motor Cover	AISI 300 SS	2	13K219				-
357	Hex Nut - Discharge Flange	AISI 300 SS	2	13K99				-
358	Plug - Seal Housing 1/4" NPT	AISI 300 SS	1	6K168				-
358E	Plug - Motor Cover 3/8" NPT	AISI 300SS	1	6K169				-
361	Retaining Ring	AISI 300 SS	1	4K375				-
361D	Seal Retainer	AISI 300 SS	1	4K379				-
371C	Skt. Hd. Screw - Brg. Hsg. to Motor Cover	AISI 300 SS	2	13K271				-
371H	Hex Cap Screw - Discharge Flange	AISI 300 SS	2	13K153				-
372D	Hex Cap Screw - Housing to Casing	AISI 300 SS	4	13K222				-
376	Capacitor (1 Phase only) - Start	Varies	1	9K197				-
383	Mechanical Seal - Upper	Carbon/Ceramic	1	10K121 (Type 16)				-
387	Mechanical Seal - Lower (Standard)	Silicon Carbide	1	10K120 (Type 16)				-
	Mechanical Seal - Lower (Optional)	Tungsten Carbide	1	10K122 (Type 16)				-
412M	O-ring - Motor Cover	BUNA-N, AS568A-166	1	4K252				-
412P	O-ring - Seal/Bearing Housing	BUNA-N, AS568A-163	1	5K181				-
457	Wire Nut	Power Cable - 3 Ph., 460V	1 pkg.	N/A	9K145 (package of 8)			-
		Seal/Heat Cable - Opt. 3 Ph. Only	1 pkg.	9K145 (package of 8)				-
458	Handle Assembly	AISI 300 SS	1	4K243				-
484	Strain Relief Assembly, Sensor Cable	Varies	1	5K113				-
484B	Strain Relief Assembly (Power Cable)	1 Phase	1	5K113		5K111		-
		3 Phase		N/A	5K111			
528	Washer - Discharge Flange	AISI 300 SS	2	13K82				-
-	Heat Sensor Kit (Optional)	-	1	9K261				-
-	Seal Installation Tool	-	1	A02A013				-
-	Loctite #271	-	1	AL27121				-

### MODELS 3888D3/3SD, 3888D4/4SD

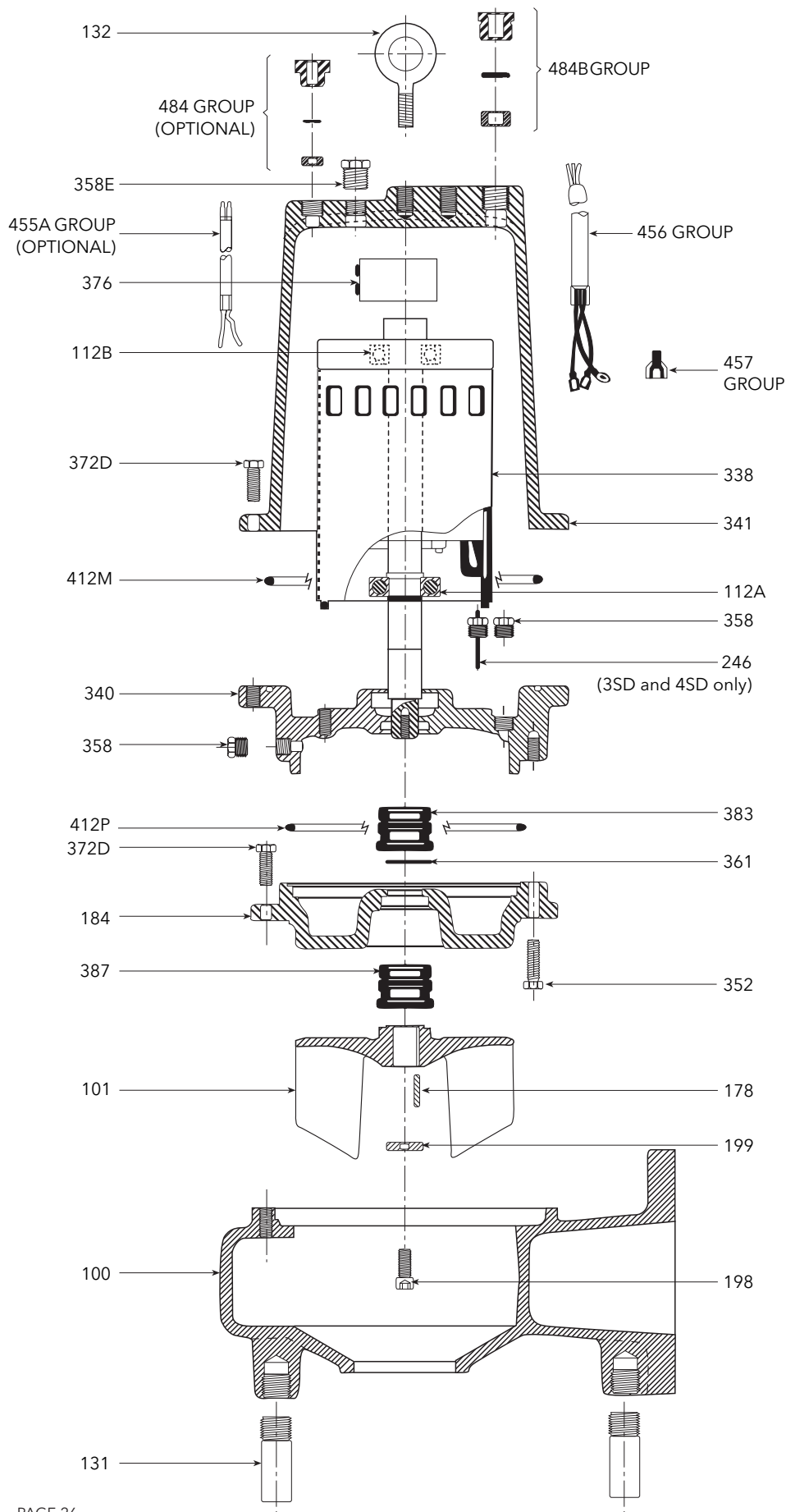

#### CAPACITOR DATA

"K" no.	MFD	VAC	Qty. Req.
9K144 <sup>①</sup>	20	370	2
9K233 <sup>②</sup>	30	370	2
9K262	50	370	2
9K332	60	370	See item 376
9K456 <sup>③</sup>	40	370	2

① Used prior to March 1991.

② Replaced by 60 mfd.

③ Used on new 1½ & 2 HP motors after May 2006 – check capacitor ratings before ordering replacements.

### MODELS 3888D3/3SD, 3888D4/4SD

Item No.	Part Description	Material	Qty. Req.	Repair Parts Order Number - 1725 RPM						Max. Wt. (Lbs.)	
				1½ HP M	1½ HP	2 HP	3 HP	5 HP	7½ HP		
100	Casing - 3888D3, 3SD	Cast Iron	1	1K190						42.0	
	Casing - 3888D4, 4SD			1K219						52.0	
101	Impeller - 3888D3, 3SD, Standard	Cast Iron	1	2K514 5¼"	2K24 6½"	2K25 7.0"	2K26 7¼"	2K27 8.0"	N/A	7.0	
	Impeller - 3888D3, 3SD, Optional	Bronze		2K515 5¼"	2K284 6½"	2K285 7.0"	2K286 7¼"	2K287 8.0"	N/A	8.0	
	Impeller - 3888D4, 4SD, Standard	Cast Iron		2K512 5½"	2K294 6¼"	2K295 6½"	2K296 7.0"	2K830 7¼"	2K532 7 <sup>11</sup> / <sub>16</sub> "	7.5	
	Impeller - 3888D4, 4SD, Optional	Bronze		2K513 5½"	2K329 6¼"	2K328 6½"	2K327 7.0"	2K326 7¼"	2K533 7 <sup>11</sup> / <sub>16</sub> "	8.5	
112A	Lower Ball Bearing	Steel	1	4K135						4K402	-
112B	Upper Ball Bearing	Steel	1	4K384						-	
131	Pump Leg - Standard	Steel	3	4K42						-	
	Pump Leg - Optional	Cast Iron	1	4K625						-	
132	Eye Bolt	Galvanized Steel	1	13K193						-	
178	Impeller Key	AISI 300 SS	1	4K11						-	
184	Seal Housing - 3888D3, 3SD	Cast Iron	1	1K189						N/A	19.0
	Seal Housing - 3888D4, 4SD	Cast Iron	1	1K218						18.0	
198	Impeller Bolt	17-4PH SS	1	13K48						-	
199	Impeller Washer	AISI 300 SS	1	13L39						-	
218	Insulating Turbine Oil	Turbine Oil - ASTM 150	-	4K432						7.5 lbs./gal.	
	Gallons required in Seal Housing			3888D3, 3SD - .44 - 3888D4, 4SD - .38							
	Gallons required in Motor Cover			1.75				1.5			
246	Seal Sensor - Available Only on 3SD, 4SD	Nylon/Brass	1	9K191						-	
338	Motor - 1 Phase, 208V	Stainless Steel Shaft	1	114-9210R	114-9210R	114-9210R	114-9210R	N/A	N/A	-	
	Motor - 1 Phase, 230V			114-925R	114-925R	114-926R	114-927R	114-928R	N/A		
	Motor - 3 Phase, 200 V			114-9230R	114-9230R	114-9230R	114-9231R	114-9232R	N/A		
	Motor - 3 Phase, 230/460 V			114-9217R	114-9217R	114-9217R	114-9218R	114-9219R	119-961R		
	Motor - 3 Phase, 575 V			114-9227R	114-9227R	114-9227R	114-9228R	114-9229R	119-963R		
340	Bearing Housing	Cast Iron	1	1K176						1K303	28.0
341	Motor Cover - 3888D3, 3888D4	Cast Iron	1	1K177						39.0	
	Motor Cover - 3SD, 4SD	Cast Iron	1	1K299						39.0	
352	Hex Cap Screw-Seal Housing to Bearing Housing	AISI 300 SS	4	13K81						-	
358	Plug - Seal Housing ¼" NPT	AISI 300 SS	2	6K168						-	
358E	Plug - Motor Cover ½" NPT	AISI 300 SS	1*	6K170						-	
361	Retaining Ring	AISI 300 SS	1	4K305						-	
372D	Hex Screw - Bearing Housing to Motor Cover and Seal Housing to Casing	AISI 300 SS	8	13K186						-	
376	Capacitor, Run - 1 Phase, 208 V	Varies	1	9K262 Qty. - 2	9K262 Qty. - 2	9K262 Qty. - 2	9K262 Qty. - 2	N/A		-	
	Capacitor, Run - 1 Phase, 230 V - 9K332, pre D06 - 2 HP, pre F06 - 1.5 HP			9K332 Qty. - 1	9K332 Qty. - 1	9K332 Qty. - 1	9K262 Qty. - 2	9K332 Qty. - 2	N/A	-	
	Capacitor, Run - 1 Phase, 230 V - 9K456, D06 - 2 HP, F06 - 1.5 HP			9K456 Qty. - 2	9K456 Qty. - 2	9K456 Qty. - 2	9K262 Qty. - 2	9K332 Qty. - 2	N/A	-	
383	Mechanical Seal - Upper	Carbon/Ceramic	1	10K21 (Type 21)						-	
387	Mechanical Seal - Lower (Standard)	Silicon Carbide	1	10K28 (Type 31)						-	
	Mechanical Seal - Lower (Optional)	Tungsten Carbide	1	10K22 (Type 31)						-	
412M	O-Ring - Bearing Housing to Motor Cover	BUNA-N, AS568A-374	1	4K242						-	
412P	O-Ring - Bearing Housing to Seal Housing	BUNA-N, AS568A-265	1	5K74						-	
457	Wire Nut (Power Cable)	Special Nylon Housing	2	9K145 (14/3 Cords), 9K252 (10/3 Cords)						N/A	-
				6	9K145 (14/4 Cords), 9K252 (10/4 Cords)						-
					2	9K145					
484	Strain Relief Assembly - Sensor Cable	Varies	1	5K113						-	
484B	Strain Relief Assembly (Power Cable)	Varies	1	5K234 (14/3 Cords), 5K355 (10/3 Cords)						N/A	-
				5K226 (14/4 Cords), 5K227 (10/4 Cords)						-	
	Seal Installation Tool - Guide	Delrin	1	A01A008						-	
	Seal Installation Tool - Driver	Delrin	1	A02A017						-	
	Loctite #271		1	AL27121						-	

\* 1 for 3SD/4SD and 2 for 3888D3/3888D4.

Power and Sensor Cables Description	Type and AWG Size	Standard Length	Optional Lengths				Wt. (lbs./5 ft.)
		20'	30'	50'	100'		
<b>Item No. 456, Power Cables</b>							
1 PH: 1½ and 2 HP, 230 V, standard with bare leads.	STOW - 14/3	9K266	9K267	9K268	9K269	0.9	
1 PH: 2 HP, 3 HP and 5 HP, 208 V, standard with bare leads.	STOW - 10/3	9K289	9K290	9K291	9K293	1.6	
3 PH: 1½, 2 HP, 3 HP (except 200 V) and 5 HP, 460 V, 575 V - bare leads.	STOW - 14/4	9K153	9K218	9K154	9K219	1.1	
3 PH: 3 HP, 200 V, 5 HP 200/230 V and all 7½ HP - bare leads.	STOW - 10/4	9K251	9K247	9K248	9K250	1.6	
<b>Item No. 455A, Sensor Cables</b>							
Mechanical Seal Sensor: Standard on 3SD and 4SD. (N/A on 3888D3 and 3888D4)	SJTOW - 16/2	9K189	9K220	9K221	9K222	0.5	
Seal/Heat Sensor: Optional on 3SD and 4SD.	SJTOW - 18/4	9K237	9K238	9K239	9K240	0.5	

MODELS 3SDX/4SDX

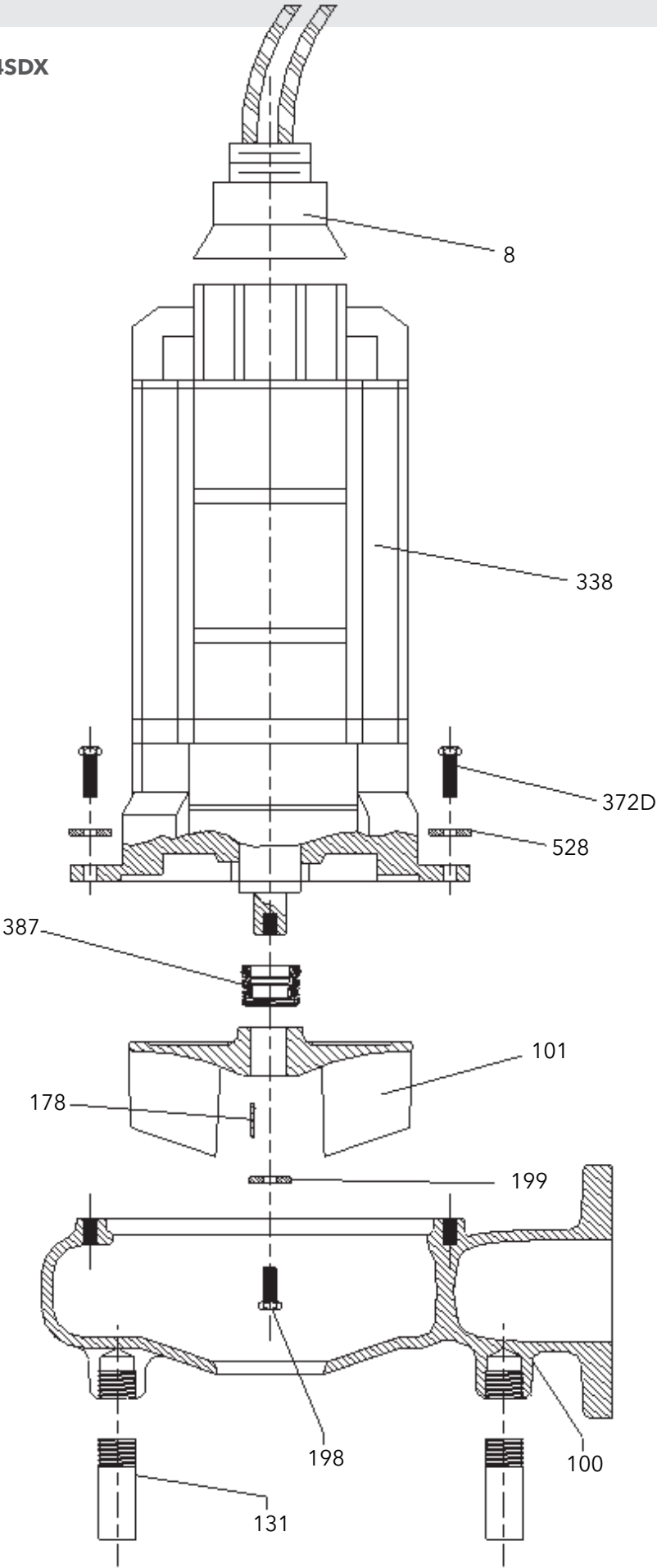

### MODELS 3SDX/4SDX

Item No.	Part Description	Material	Qty. Req'd.	Repair Parts Order Number					Max. Wt. (lbs.)	
				1750 RPM						
				1½ HP	2 HP	3 HP	5 HP	7½ HP		
100	Casing - 3SDX	Cast Iron	1	1K429					35.0	
	Casing - 4SDX			1K428					53.0	
101	Impeller - 3SDX	Cast Iron	1	2K918 5 <sup>13</sup> / <sub>16</sub> "	2K916 6 <sup>1</sup> / <sub>8</sub> "	2K914 6 <sup>3</sup> / <sub>4</sub> "	2K912 7 <sup>5</sup> / <sub>8</sub> "	2K910 8 <sup>5</sup> / <sub>16</sub> "		
	Impeller - 3SDX	Bronze		2K919 5 <sup>13</sup> / <sub>16</sub> "	2K917 6 <sup>1</sup> / <sub>8</sub> "	2K915 6 <sup>3</sup> / <sub>4</sub> "	2K913 7 <sup>5</sup> / <sub>8</sub> "	2K911 8 <sup>5</sup> / <sub>16</sub> "		
	Impeller - 4SDX	Cast Iron		N/A	2K904 5 <sup>11</sup> / <sub>16</sub> "	2K906 6 <sup>5</sup> / <sub>16</sub> "	2K908 7 <sup>1</sup> / <sub>8</sub> "	2K532 7 <sup>11</sup> / <sub>16</sub> "		
	Impeller - 4SDX	Bronze			2K905 5 <sup>11</sup> / <sub>16</sub> "	2K907 6 <sup>5</sup> / <sub>16</sub> "	2K909 7 <sup>1</sup> / <sub>8</sub> "	2K533 7 <sup>11</sup> / <sub>16</sub> "		
131	Foot - Standard	Steel	3	4K42					-	
	Foot - Optional	Cast Iron	1 Kit	4K625					-	
178	Impeller Key	AISI 300 SS	1	4K11					-	
198	Impeller Bolt	17-4 PH	1	13K48					-	
199	Impeller Washer	AISI 300 SS	1	13L39					-	
338	Motor	Stainless Steel	1	1 Phase, 230V	278-72 12	278-72 22	278-72 32	N/A	N/A	180TY 200 lbs. Air Filled
				3 Phase, 200V	278-72 13	278-72 23	278-72 33	278-72 43	278-72 53	
				3 Phase, 230V	278-72 14	278-72 24	278-72 34	278-72 44	278-72 54	
				3 Phase, 460V	278-72 15	278-72 25	278-72 35	278-72 45	278-72 55	
				3 Phase, 575V	278-72 16	278-72 26	278-72 36	278-72 46	278-72 56	
372D	Hex Cap Screw - Casing to Motor	AISI 300 SS	8	13K304					-	
NEW STYLE	387	Mechanical Seal - Standard	Carbon/Ceramic	1	10K137 (180TY)					-
		Mechanical Seal - Optional	Silicon/Silicon	1	10K134 (180TY)					
		Mechanical Seal - Optional	Silicon/Tungsten	1	10K135 (180TY)					
OLD STYLE	387	Mechanical Seal - Standard	Carbon/Ceramic	1	10K136 (140TY)					-
		Mechanical Seal - Optional	Silicon/Silicon	1	10K132 (140TY)					
		Mechanical Seal - Optional	Silicon/Tungsten	1	10K133 (140TY)					
528	Lockwasher	AISI 300 SS	8	13K158					-	

Reliance	Part Description	Material	Quantity	Repair No.	Motor Frame
Motor Repair Parts	Mechanical Seal Kit - Upper & Lower	Carbon/Ceramic	1 Set	10K183	180TY
	Bearing Kit - Upper & Lower	Steel	1 Set	4K700	
	O-Ring Kit	BUNA-N	1 Set	5K422	

Item No.	Models 3SDX/4SDX, Power and Control Cap/Cables	Type and AWG Size	Standard length	Optional Lengths	Wt. (lbs./5 ft.)
			25'	50'	
8	1 PH: 1½ HP, 230V, 140TY	SOW, SOOW - 10/4	9K357	9K358	
	1 PH: 1½, 2 and 3 HP, 230V, 180TY	SOW, SOOW - 8/4	9K359	9K360	
	3 PH: 1½, 2 and 3 HP, 200-230/460/575V, 140TY	SOW, SOOW - 14/4	9K361	9K362	
	3 PH: 5 HP, 200-230/460V, 180TY	SOW, SOOW - 12/4	9K365	9K366	
	3 PH: 7½ HP, 200-230/460V, 180TY	SOW, SOOW - 10/4	9K367	9K368	
	3 PH: 5 and 7½ HP, 575V, 180TY	SOW, SOOW - 14/4	9K363	9K364	
	3 PH: 1½, 2 and 3 HP, 200, 230, 460, 575V, 180TY	SOW, SOOW - 14/4	9K363	9K364	

Control Cable is AWG Size 18/5 - SOW.

## Wastewater

### MODEL 1GD

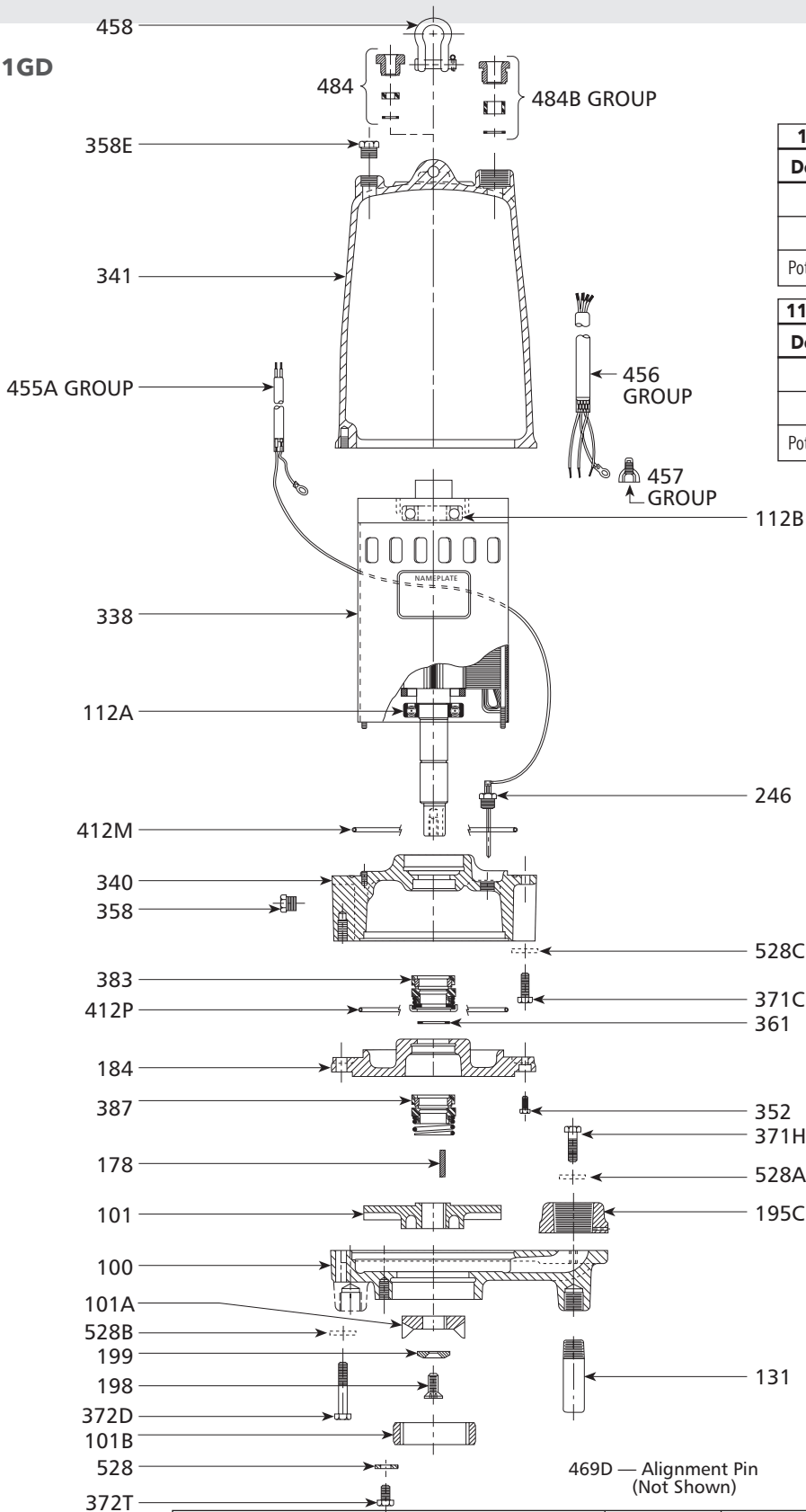

114-92 New Capacitor Package - 10/05			
Description	Repair	MFD	VAC
Start Cap		238	330
Run Cap	CP1GDB	50	370
Potential Relay		155031 - 102 or 110	

114-92 Old Capacitor Package - Pre 10/05			
Description	Repair	MFD	VAC
Start Cap		594	125
Run Cap	CP-1B	30	370
Potential Relay		RB60 (155031 - 102)	

Item No. 456, Power Cables	Type and AWG Size	Standard length				Wt. (lbs./5 ft.)
		20'	30'	50'	100'	
1 and 3 PH: 2 HP, 200-230/460/575V with bare leads.	STOW - 14/4	9K153	9K218	9K154	9K219	1.1
Item No. 455A, Sensor Cables						
Mechanical Seal Sensor - Optional	SJTOW - 16/2	9K189	9K220	9K221	9K222	0.5
Heat Sensor - Standard 1 Phase, Optional 3 Phase.	SJTOW - 16/2	9K189	9K258	9K259	9K260	0.5
Mechanical Seal/Heat Sensor - Optional	SJTOW - 18/4	9K237	9K238	9K239	9K240	0.5

### MODEL 1GD

Item No.	Part Description	Material	Quantity Required	Repair Parts Order Number	Weight (lbs.)
100	Casing	Cast Iron	1	1K174	10.5
101	Impeller - 8th Digit Model Designation and Diameter	Bronze	1	2K247 A = 5 $\frac{5}{8}$ "	3.0
				2K332 B = 5 $\frac{1}{4}$ "	
				2K333 C = 4 $\frac{3}{4}$ "	
				2K334 D = 4 $\frac{1}{4}$ "	
101A	Cutter	AISI 440C SS	1	4K303	0.5
101B	Cutter Ring	AISI 440C SS	1	4K304	0.5
112A	Lower Ball Bearing	Steel	1	4K135	-
112B	Upper Ball Bearing	Steel	1	4K384	-
131	Foot - Standard	Steel	3	4K343	-
	Foot - Optional	Cast Iron	1 Kit	4K639	
178	Impeller Key	AISI 300 SS	1	4K11	-
184	Seal Housing	Cast Iron	1	1K226	8.5
195C	Discharge Flange	Cast Iron	1	4K313	1.0
198	Impeller Screw	AISI 300 SS	1	13K190	-
199	Impeller Washer	AISI 300 SS	1	13K191	-
218	Insulating Oil - Gallons Required	Turbine Oil - ASTM150	-	4K245	7.5 lbs./gal.
	Gallons Required in Seal Housing			0.98	
	Gallons Required in Motor Cover			0.23	
246	Seal Sensor - Plug and Rod (See Note)	Nylon/Brass	1	9K191	-
338	Motor - 1 Phase, 208V	Stainless Steel Shaft	1	114-921R	26.0 to 40.0
	Motor - 1 Phase, 230V			114-921R	
	Motor - 3 Phase, 200V			114-9220R	
	Motor - 3 Phase, 230/460V			114-9212R	
	Motor - 3 Phase, 575V			114-9292R	
340	Bearing Housing	Cast Iron	1	1K227	14.5
341	Motor Cover with Seal Sensor (See Note)	Cast Iron	1	1K197	23.0
	Motor Cover without Seal Sensor (See Note)			1K209	
352	Screw - Seal Housing to Bearing Housing	AISI 300 SS	2	13K347	-
358	Plug - Bearing Housing $\frac{1}{4}$ " NPT	AISI 300 SS	1	6K168	-
358E	Plug - Motor Cover $\frac{3}{8}$ " NPT	AISI 300 SS	1	6K169	-
361	Retaining Ring	Steel	1	4K305	-
371C	Hex Cap Screw - Brg. Hsg. to Motor Cover	AISI 300 SS	4	13K78	-
371H	Hex Cap Screw - Discharge Flange to Casing	AISI 300 SS	2	13K186	-
372D	Hex Cap Screw - Casing to Bearing Housing	AISI 300 SS	4	13K52	-
372T	Hex Cap Screw - Cutter Ring Retainer	AISI 300 SS	3	13K218	-
383	Mechanical Seal - Upper	Carbon/Ceramic	1	10K21 (Type 21)	-
387	Mechanical Seal - Lower (Standard)	Silicon Carbon	1	10K28 (Type 31)	-
	Mechanical Seal - Lower (Optional)	Tungsten Carbon		10K22 (Type 31)	
412M	O-ring - Motor Cover	BUNA-N, AS568A-166	1	4K252	-
412P	O-ring - Seal/Bearing Housing	BUNA-N, AS568A-256	1	5K73	-
457	Wire Nut	Nylon Housing	Power Cable - 1 Ph., 230V	3	9K145
			Power Cable - 3 Ph., 200/230V	4	
			Power Cable - 3 Ph., 460V	6	
			Power Cable - 3 Ph., 575V	3	
			Seal/Heat Cable - See Note	2	
458	Lifting Handle	304 SS	1	4K494	-
469D	Alignment Roll Pin (Not Shown)	Steel	2	9K265	-
484	Strain Relief Assembly, Sensor Cable (See Note)	Varies	1	5K113	-
484B	Strain Relief Assembly, Power Cable	Varies	1	5K111	-
528	Washer - Cutter Ring Retainer	AISI 300 SS	3	13K212	-
528A	Lockwasher - Discharge Flange to Casing	AISI 300 SS	2	13K158	-
528B	Lockwasher - Casing to Bearing Housing	AISI 300 SS	4	13K158	-
528C	Lockwasher - Bearing Housing to Motor Cover	AISI 300 SS	4	13K117	-
-	Heat Sensor Kit (See Note)	-	1	9K261	-
-	Seal Installation Tool - Guide	Delrin*	1	A01A008	-
-	Seal Installation Tool - Driver	Delrin*	1	A02A017	-
-	Loctite* #271	-	1	AL27121	-

**Notes:** 1 phase (Old 114-92 #2 motor) has Heat Sensor (93711) supplied with motor, Goolds Water Technology 3 phase is optional, Marlow 3 phase is standard.

New 1 Phase 114-92 #1 motor has in-line thermal protector

Old 1 Phase 114-92 #2 motor had pilot duty thermal protector

**MODELS 4NS/4XD with Reliance Motors**

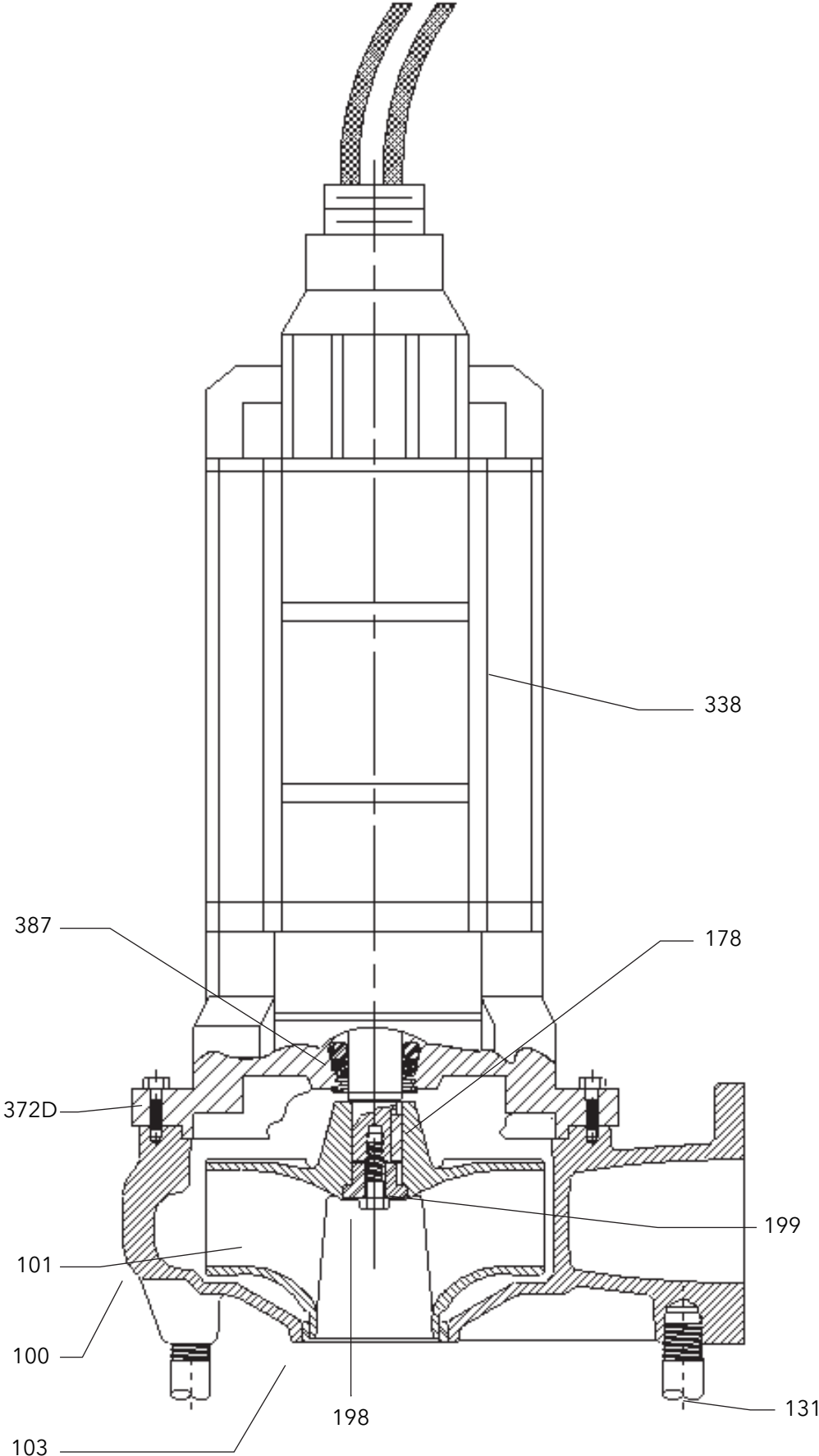



### MODELS 4NS/4XD with Reliance Motors

Item No.	Part Description	Material	Qty. Req'd.	Repair Parts Order Number								Max. Wt. (lbs.)		
				1750 RPM				1150 RPM						
				7½ HP	10 HP	15 HP	20 HP	25 HP	30 HP	40 HP	7½ HP		10 HP	
100	Casing - with Wear Ring	Cast Iron	1	1K326								75.0		
101	Impeller - 4NS/4XD	Cast Iron		2K781 7½"	2K779 8"	2K776 9"	2K774 9¾"	2K772 10⅝"	2K771 10¾"	2K770 11"	2K773 10⅝"	2K770 11"	21.5-	
	Impeller - 4NS/4XD	Bronze		2K795 7½"	2K793 8"	2K790 9"	2K788 9¾"	2K786 10⅝"	2K785 10¾"	2K784 11"	2K787 10⅝"	2K784 11"	25.0-	
103	Casing Wear Ring	Bronze	1	4K264								2.0		
131	Foot - Standard	Steel	3	4K367 (Old), 4K42 (New)								2.0		
	Foot - Optional	Cast Iron	1 Kit	4K625								-		
178	Impeller Key	AISI 300 SS	1	4K392								-		
198	Impeller Bolt	AISI 300 SS	1	13K275								-		
199	Impeller Washer	AISI 300 SS	1	4K431								-		
338	Motor	3 Phase, 200V	Replace 279-26 with 279-27 for UL listed Explosion Proof Motor. Index Suffixes are the same.	1	279-261 (210TY)	279-2611 (210TY)	279-2621 (210TY)	279-2631 (210TY)	279-2641 (250TYS)	279-2651 (250TYS)	279-2661 (250TYS)	279-2671 (210TY)	279-2681 (210TY)	210TY 315 lbs. Air Filled 250TYS 750 lbs. Air Filled
				279-262 (210TY)	279-2612 (210TY)	279-2622 (210TY)	279-2632 (210TY)	279-2642 (250TYS)	279-2652 (250TYS)	279-2662 (250TYS)	279-2672 (210TY)	279-2682 (210TY)		
				279-263 (210TY)	279-2613 (210TY)	279-2623 (210TY)	279-2633 (210TY)	279-2643 (250TYS)	279-2653 (250TYS)	279-2663 (250TYS)	279-2673 (210TY)	279-2683 (210TY)		
				279-264 (210TY)	279-2614 (210TY)	279-2624 (210TY)	279-2634 (210TY)	279-2644 (250TYS)	279-2654 (250TYS)	279-2664 (250TYS)	279-2674 (210TY)	279-2684 (210TY)		
				279-265 (210TY)	279-2615 (210TY)	279-2625 (210TY)	279-2635 (210TY)	279-2645 (250TYS)	279-2655 (250TYS)	279-2665 (250TYS)	279-2675 (210TY)	279-2685 (210TY)		
372D	Hex Cap Screw - Casing to Motor	AISI 300 SS	8	13K45								-		
387	Mechanical Seal - Standard	Carbon/Ceramic	1	10K157				10K160		10K157		-		
	Mechanical Seal - Optional	Silicon/Silicon	1	10K158				10K161		10K158				
	Mechanical Seal - Optional	Silicon/Tungsten	1	10K159				10K162		10K159				

Power and Control Cap/Cables for Reliance Motors	Type and AWG Size	Standard length		Optional Lengths		Wt. (lbs./5 ft.)
		25'		50'		
	SOW, SOOW 14/4	9K423		9K431		
	SOW, SOOW 12/4	9K424		9K432		
	SOW, SOOW 10/4	9K425		9K433		
	SOW, SOOW 8/4	9K426		9K434		
	SOW, SOOW 6/4	9K427		9K435		
	SOW, SOOW 4/4	9K428		9K436		
	SOW, SOOW 2/4	9K429		9K437		
	SOW, SOOW 1/0/4	9K430		9K438		

Control Cable is AWG Size 18/5 - SOW-A, SO.

Parts for Pumps with USEM Motors							
372E	Hex Cap Screw - Bracket to Motor	AISI 300 SS	2	13K226	13K277	13K226	-
387	Mechanical Seal - Optional	Carbon/Ceramic	1	10K82	10K142	10K82	-
	Mechanical Seal - Optional	Silicon/Tungsten	1	10K83	10K85	10K83	-
458	Lift Bracket	AISI 300 SS	1	4K433	4K434	4K433	3.5

Reliance	Part Description	Material	Quantity	Repair No.	Motor Frame	Repair No.	Motor Frame
Motor Repair Parts	Mechanical Seal Kit - Upper & Lower	Carbon/Ceramic	1 Set	10K181	210TY	10K182	250TY
	Bearing Kit - Upper & Lower	Steel	1 Set	4K698		4K699	
	O-Ring Kit	BUNA-N	1 Set	5K420		5K421	

### MODEL RGS2012

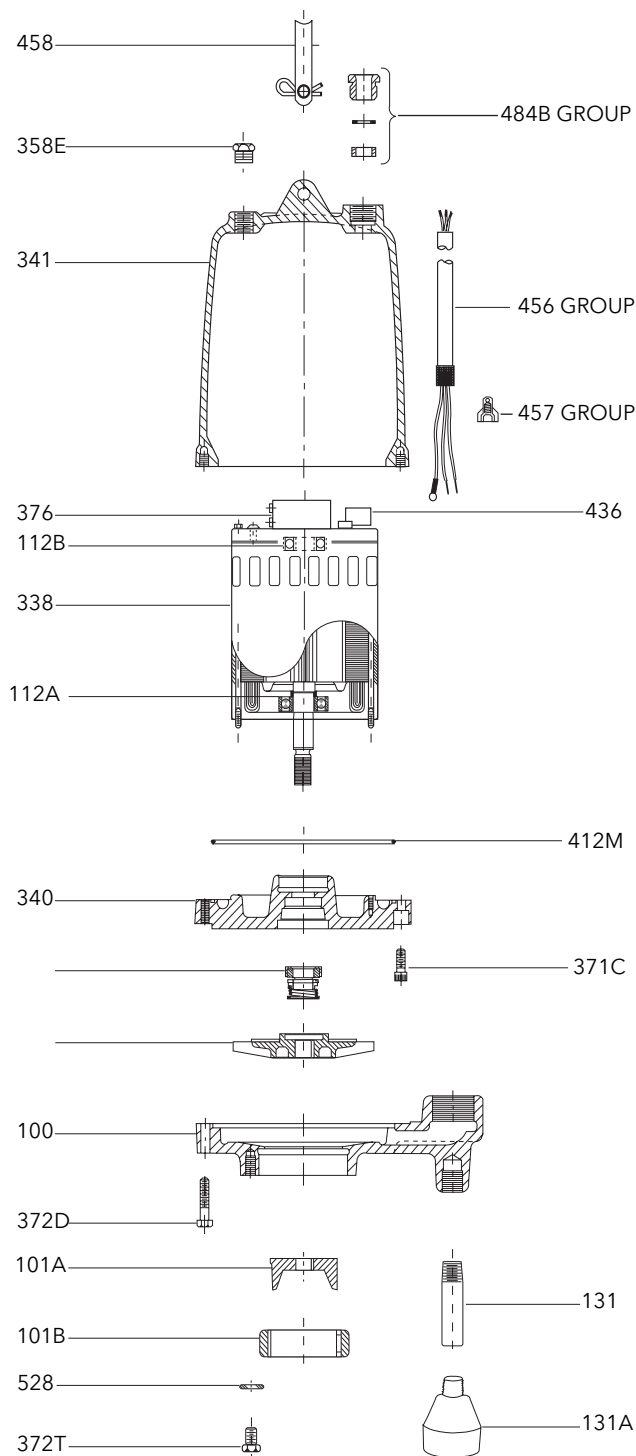

Item No.	Part Name	Material	Qty.	Repair Parts Order Number	Wt. (lbs.)
100	Casing	Cast iron	1	1K313	11
101	Impeller 5.69" dia.	Bronze	1	2K705	2.0
101A	Cutter with shims	AISI 440C SS	1	4K409	0.5
101B	Cutter ring	AISI 440C SS	1	4K304	0.5
112A	Lower ball bearing	Steel	1	4K384	-
112B	Upper ball bearing	Steel	1	4K132	-
131	Foot	Steel	3	4K343	-
131A	Optional Pump Legs	Steel	3	4K639	-
218	Insulating oil	Turbine Oil ASTM150	.98 gal	4K432 See Index Page	7.5 lbs/gal
338	Motor with Brg. Hsg. #340	-	-	120-212R	19
340	Bearing housing	Cast iron	-		
341	Motor cover - Use with cord with NEMA plug	Cast iron	1	1K207	18.5
	power cable without plug			1K208	
358E	Plug - motor cover 3/8" NPT	AISI 300 SS	1	6K169	-
371C	Screw - bearing housing to motor cover	AISI 300 SS	4	13K271	-
372D	Screw - casing to bearing housing	AISI 300 SS	4	13K336	-
372T	Screw - cutter ring retainer	AISI 300 SS	3	13K218	-
376	Capacitor (start)	-	1	9K353	-
387	Mechanical seal (standard)	Silicon Carbide	1	10K119	-
	Mechanical seal (optional)	Tungsten Carbide		10K123	-
412M	O-ring - motor cover	BUNA-N	1	4K252	-
436	Solid state switch	-	1	9K395	-
456	Power cable	-	1	See power cable chart	-
457	Wire nut	Nylon	2	9K145	-
458	Handle assembly	AISI 300 SS	1	4K243	-
484B	Strain relief assembly - power cable with plug	Varies	1	5K113	-
	power cable without plug			5K111	-
528	Washer - cutter ring retainer	AISI 300 SS	3	13K212	-

### RESIDENTIAL GRINDER POWER CABLES

Residential Grinder Power Cables	Standard length	Optional Lengths			Wt. (lbs./5 ft)
	20'	30'	50'	100'*	
1 Phase, 2 HP, 230V - STOW - 14/3 with bare leads	9K266	9K267	9K268	9K269	0.9
1 Phase, 2 HP, 230V - SJTOW - 14/3 with Nema plug	9K393	9K394	N/A	N/A	0.9

\* Maximum allowable cord length. \*\* Includes 230V NEMA plug.

9K353 capacitor is a 295/355 MFD, 125 VAC start capacitor with resistor.

### MODEL AGS0511/AGS0512

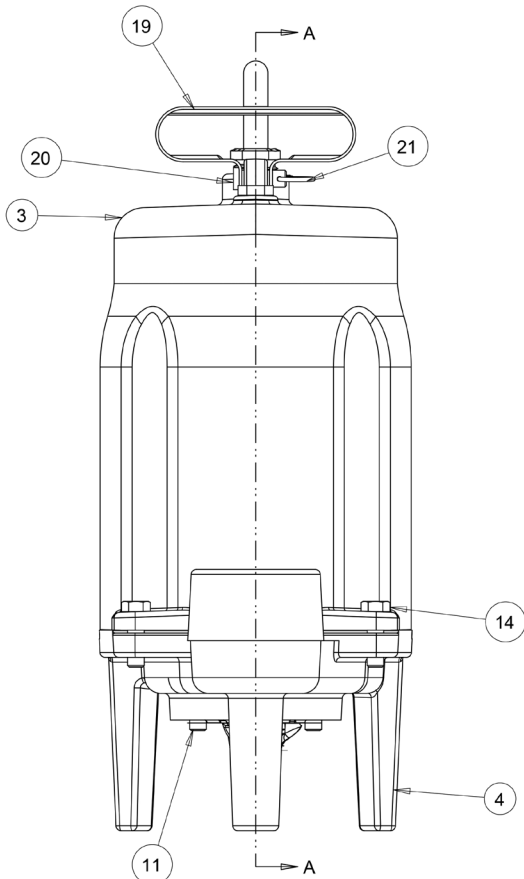
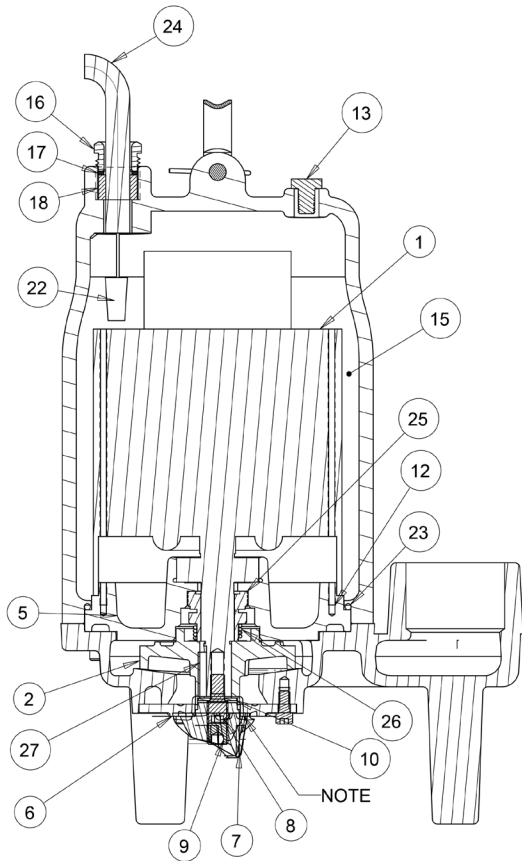

ITEM #	DESCRIPTION	REPAIR PART #	QUANTITY
1	1 hp 1/60/115/208-230/3450	9K816	1
2	Impeller AGS 0.5 hp	2K1296	1
3	Motor cover	1K1118	1
4	Casing	1K1119	1
5	Bearing housing	1K1120	1
6	Cutter ring - 8 hole	15L64	1
7	Rotating cutter wheel		1
8	Impeller & cutter wheel screw M12/M8		1
9	Cutter wheel locking screw M12 x 12		1
10	Washer/shim 8.5 ID x 22 OD x 1.5 W		1
11	Cutter ring SKT head cap screw 1/4-20 x .5"		3
12	Roll pin 3/16" x 1 3/8"	13K406	1
13	3/8" NPT pipe plug SS	6K169	1
14	Hex cap screw 3/8" x 1.25"	13K462	4
15	Insulating oil (gallons)	4K432	0.50
16	Gland nut	5K111	1
17	Gland washer	5K554	2
18	Strain relief packing	5K553	1
19	Handle	4K243	1
20	Handle pin		1
21	Hair pin		1
22	Wire nut	9K145	2
23	O-ring bun	4K252	1
24	Cord set - 230V plug	9K393	1
	Cord set - 115V plug	9K771	1
25	Mech seal stat .75" Silcar/Buna type 16	10K119	1
26	Mech seal rot .75" Silcar/Buna type16		1
27	Key 3/16" x 1" long	4K1238	1

**NOTE:** 0.004" - 0.006" clearance between cutter wheel and cutter ring

### MODEL AGS1011/AGS1012

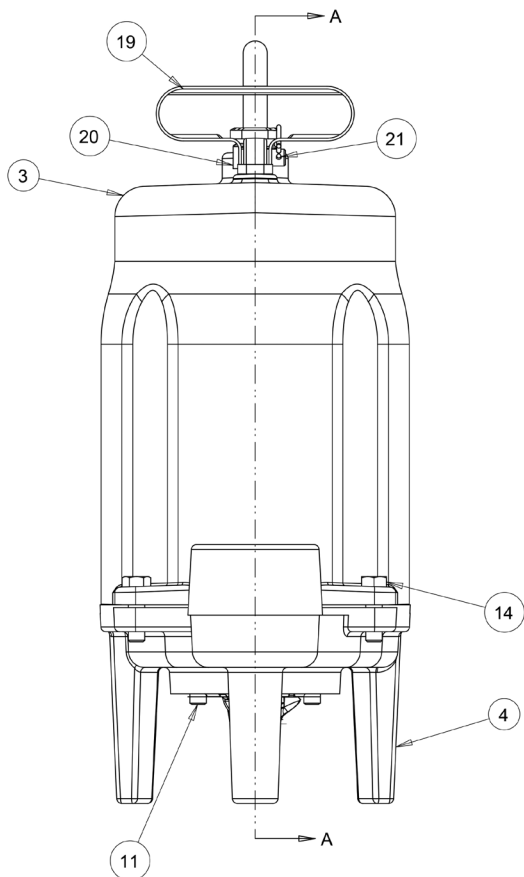
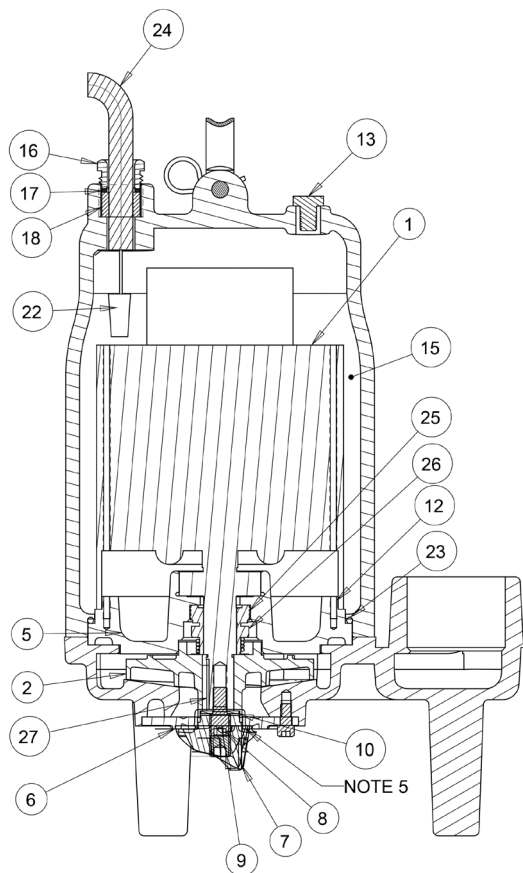

ITEM #	DESCRIPTION	REPAIR PART #	QUANTITY
1	1 hp 1/60/115/208-230/3450	9K816	1
2	Impeller AGS 1 hp	2K1296	1
3	Motor cover	1K1118	1
4	Casing	1K1119	1
5	Bearing housing	1K1120	1
6	Cutter ring - 8 hole	15L64	1
7	Rotating cutter wheel		1
8	Impeller & cutter wheel screw M12/M8		1
9	Cutter wheel locking screw M12 x 12		1
10	Washer/shim 8.5 ID x 22 OD x 1.5 W		1
11	Cutter ring SKT head cap screw 1/4-20 x .5"		3
12	Roll pin 3/16" x 1 3/8"	13K406	1
13	3/8" NPT pipe plug SS	6K169	1
14	Hex cap screw 3/8" x 1.25"	13K462	4
15	Insulating oil (gallons)	4K432	0.50
16	Gland nut	5K111	1
17	Gland washer	5K554	2
18	Strain relief packing	5K553	1
19	Handle	4K243	1
20	Handle pin		1
21	Hair pin		1
22	Wire nut	9K145	2
23	O-ring bun	4K252	1
24	Cord set - 230V plug	9K393	1
	Cord set - 115V plug	9K771	1
25	Mech seal stat .75" Silcar/Buna type 16	10K119	1
26	Mech seal rot .75" Silcar/Buna type16		1
27	Key 3/16" x 1" long	4K1238	1

### MODELS 1GA/2GA

Pump	Impeller Code	Phase	Impeller	Repair Kit	Inner Seal	Outer Seal	Cutter Wheel	Cutter Ring
3 hp	H	1	2K1227	5K481	10K201	10K208	4K812	4K814
3 hp	L	1	2K1228					4K818
5.4 hp	G	1	2K1229	5K482	10K202	10K207	4K813	4K817
5.4 hp	K	1	2K1230					4K816
9.4 hp	J	1	2K1225	5K483	10K205	10K209		4K819
9.4 hp	F	1						4K816
4 hp	C	3	2K1222	5K505	10K201	10K206	4K812	4K814
6 hp	B	3	2K1223	5K482	10K202	10K207	4K813	4K815
6 hp	E	3	2K1224					4K816
11 hp	A	3	2K1226	5K480	10K204	10K205		4K817
11 hp	D	3	2K1225					4K816

Repair Kit includes: Seals, O-rings, Bearings

O-Ring Kit includes all O-rings

### SUMP, EFFLUENT AND SEWAGE REPAIR PARTS OIL VOLUMES

Model	Oil Volume - Motor Housing	Oil Volume - Seal Housing
	Quarts	Quarts
ST 31	1.32	N/A
PE31	1.32	N/A
PE41	1.32	N/A
PE51	1.32	N/A
PS41	1.70	N/A
PS51, PV51	1.70	N/A
3871 (EP's - .4 hp)	1.00	N/A
3871 (EP's - .5 hp)	0.85	N/A
3872 (WW's)	0.85	N/A
3885 (WE's) - A.O. Smith	3.90	N/A
3885 (WE's) - Franklin	3.50	N/A
2ED's - A.O. Smith	3.90	0.40
3886 (WS—B)	3.90	N/A
3887BF (WS—BF)	3.90	N/A
3887BHF (WS—BHF) - A.O. Smith	3.90	N/A
3887BHF (WS—BHF) - Franklin	3.50	N/A
2/3WD's - A.O. Smith	3.90	0.40
3888D3 (WS—D3)	7.00	1.70
3SD's	7.00	1.70
3888D4 (WS—D4)	7.00	1.50
4SD's	7.00	1.50
3888D4 (WS—D4) - 7½ hp	6.00	1.50
4SD's - 7½ hp	6.00	1.50
RGS2012	3.90	N/A
1GD - Single Phase	3.55	0.90
1GD - Three Phase	3.90	0.90

Noco T-32 oil is standard.

**Note:** Normally a minimum of a 1" air gap at the top of the motor/seal housing should be maintained due to thermal expansion of the oil.

Please contact Customer Service for part information: Phone (866) 325-4210 or Fax (888) 322-5877 (toll free).

### CONTROL PANEL REPAIR PARTS

RB Number*	Description	Control Panel	Manufacturer Name and Part Number
RB-1*	Single Phase Contactor, 2 Pole	Use RB-81*	Furnas, 41NB20AFP
RB-4	Pump Circuit Breaker	SIFGC3-DIFGC3	Square D, QOU240
RB-5	Pump Circuit Breaker	SIFGC5-DIFGC5	Square D, QOU260
RB-6	Pump Circuit Breaker	A6-2012	Square D, QOU220
RB-24	Three Phase Contactor, 3 Pole	D3-S3	ABB DP30C3P-1/B
RB-25	Three Phase Contactor with Aux		ABB DP30C3P-CADP40-10
RB-30	Control Circuit Breaker	A6-2012	Square D - QOU110
RB-31	Seal Sensor Relay	A4-3, A4-4	BFI-SFR-120
RB-32*	Single Phase Contactor, 2 Pole	Use RB-24*	Furnas, 41NB20AFMGR
RB-34	Control Circuit Transformer	3 Phase Panels	Micron B100BTZ13JK
RB-35	Time Delay Relay	A6-1012, A6-2012	SSAC, TSD 74115
RB-36	Control Relay		Eaton D5PR3A
RB-37	Pump Circuit Breaker		Square D - QOU115
RB-38	Pump Circuit Breaker		Square D - QOU215
RB-39	Control Circuit Breaker		Square D - QOU210
RB-40	Pump Circuit Breaker		Square D - QOU330
RB-41	Control Circuit Breaker	A642510	Carling Switch EA2-B0-26-610-32E-GB
RB-42	Pump Circuit Breaker	A642510	Carling Switch EA2-B0-26-610-32E-GB
RB-46*	Three Phase Contactor, 3 Pole	Use RB-25*	Furnas, 41NB30AFMGR
RB-47*	Three Phase Contactor, 3 Pole	Use RB-24*	Furnas, 41NB30AFP
RB-50	Alarm Horn	All SES Control Panels	Floyd, MC-09-201-QC
RB-51	Control Relay	LAN4-LAN1	Sky SKMP-2C-120VAC
RB-52	Motor Circuit Protector	S31625, D31625	Eaton XTPR2P5BC1
RB-53	Motor Circuit Protector	S32540, D32540	Eaton XTPR004BC1
RB-54	Motor Circuit Protector	S34063, D34063	Eaton XTPR6P3BC1
RB-55	Motor Circuit Protector	S36310, D36310	Eaton XTPROLOBCL
RB-56	Motor Circuit Protector	S31016, D31016	Eaton XTPR016BC1
RB-57	Motor Circuit Protector	S31620, D31620	Eaton XTPR020BC1
RB-58	Motor Circuit Protector	S32025, D32025	Eaton XTPR025BC1
RB-59	Overload Relay		Furnas, 48DA18AA4
RB-60	Motor Start Relay	D1GD2	Franklin Electric, 155031102
RB-61	Motor Start Capacitor	D1GD2	216-259 UF
RB-62	Motor Run Capacitor	D1GD2	50 @ 370 VAC
RB-70	Flashing Red Alarm Light	All S31625-S32025 S10020, S10020NL D10020, D10020NL	Ingram Products, MX-15
RB-71	Flashing Red Alarm Light	All D31625-D32025 D12127, D12836	Ingram Products, LRX-25
RB-72*	Pump Run Light Assembly	Use RB-77G*	ZB5AV033 with LED

\* Indicates obsolete component. Use suggested replacement.

*Continued on next page*

### CONTROL PANEL REPAIR PARTS (continued)

RB Number*	Description	Control Panel	Manufacturer Name and Part Number
RB-73	Alarm Test Button Assembly	All SES Panels Except S10020NI, D10020NI	ABB, CPLLOR-11
RB-74	Alarm Reset Button	D10020, D12127, D12836 D31625-D32025	ABB, CPL OG-11
RB-75	Duplex Logic Control Board	All SES Duplex Panels	BFL-LLC-120
RB-76	Alarm Silence Button	All SES Panels Except D10020NL, S10020NL	ABB, CPLLOG-11
RB-77G	Green LED Complete	All SES Panels Except D10020NL, S10020NL	ABB, CL-S13G
RB-77W	White LED Complete		ABB, CL-513W
RB-77R	Red LED Complete Assembly		ABB, CL-513R
RB-78	Pump Circuit Breaker	D10020NL, DL0020	Square D, QOU-225
RB-80	Simplex Logic Control Board		BFL-LLC-120-SIM
RB-81	Contactor	S10020, S10020N1 D10020, D10020NL	ABB, DP30C2P-1
RB-82	Fuse		ATDR2
RB-83	Alternator		TARS

\* Indicates obsolete component. Use suggested replacement.

### A10-12, A10-2015 and A10-20

Item No.	Description	A10-12	A10-20 and A2015
1	Upper Guide Bracket	4K800	4K801
2	Brass Qick Disconnect	4K802	4K803
3	Cl Ball Check Valve	4K804	4K805
4	O-Ring Disconnect	4K806	4K807
5	Movable Side	4K808	4K809
6	Lower Stand Off	4K810	4K811

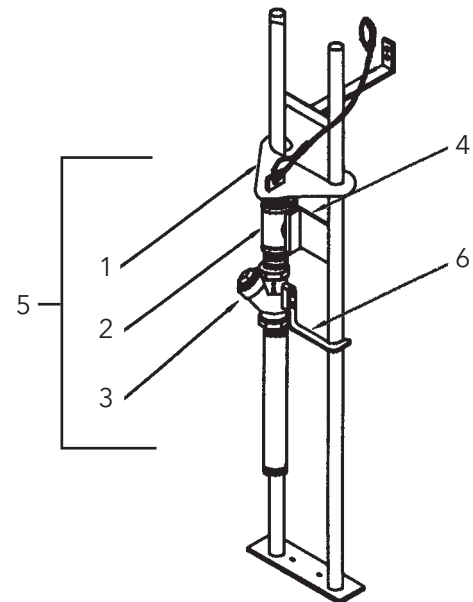

# Xylem |'zīləm|

- 1) The tissue in plants that brings water upward from the roots;
- 2) a leading global water technology company.

We're a global team unified in a common purpose: creating advanced technology solutions to the world's water challenges. Developing new technologies that will improve the way water is used, conserved, and re-used in the future is central to our work. Our products and services move, treat, analyze, monitor and return water to the environment, in public utility, industrial, residential and commercial building services settings. Xylem also provides a leading portfolio of smart metering, network technologies and advanced analytics solutions for water, electric and gas utilities. In more than 150 countries, we have strong, long-standing relationships with customers who know us for our powerful combination of leading product brands and applications expertise with a strong focus on developing comprehensive, sustainable solutions.

**For more information on how Xylem can help you, go to [www.xylem.com](http://www.xylem.com)**



Xylem Inc.  
2881 East Bayard Street Ext., Suite A  
Seneca Falls, NY 13148  
Phone: (866) 325-4210  
Fax: (888) 322-5877  
[www.xylem.com/goulds](http://www.xylem.com/goulds)

Goulds is a registered trademark of Goulds Pumps, Inc. and is used under license.  
© 2019 Xylem Inc. RSES R14 October 2019